

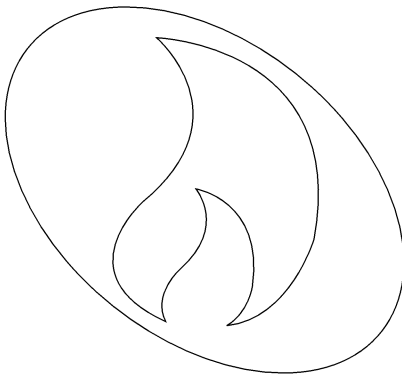

**installation & operating  
instructions and cooking  
guidance**

**Single oven  
with gas hobs**

Model    GCF60  
            GCWF60



*get the best from your new cooker*

## **Please read these instructions before installation or using your appliance!**

Dear Customer,

By purchasing this product you have chosen an appliance of advanced technology and high quality.

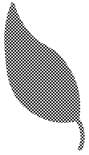

The appliance was produced in modern facilities which meet all environmental standards.

The instructions will help you to operate the appliance quickly and safely.

- Upon delivery, please check that the appliance is not damaged. If you note any transport damage, please contact your point of sale immediately and do not connect and operate the appliance!
- Before you connect and start using the appliance, please read this manual and all enclosed documents. Please note in particular the safety instructions.
- Keep all documents so that you can refer to the information again later on. Please keep your receipt for any repairs which may be required under warranty.
- When you pass on the appliance to another person, please provide all documents with it.

# Table of Contents

---

|                 |   |                  |                                       |   |                  |
|-----------------|---|------------------|---------------------------------------|---|------------------|
| <b><u>1</u></b> | <b><u>General information</u></b>         | <b><u>4</u></b>  | First cleaning of the appliance ..... | 19                                      |                  |
|                 | Overview .....                            | 4                | Initial heating .....                 | 19                                      |                  |
|                 | Technical Data .....                      | 5                | <b><u>5</u></b>                       | <b><u>How to use the hob</u></b>        | <b><u>20</u></b> |
|                 | Accessories supplied with the unit.....   | 6                |                                       | General information on cooking.....     | 20               |
|                 | Injector Table .....                      | 6                |                                       | How to use hobs.....                    | 20               |
| <b><u>2</u></b> | <b><u>Safety Instructions</u></b>         | <b><u>7</u></b>  | <b><u>6</u></b>                       | <b><u>How to Operate the Oven</u></b>   | <b><u>22</u></b> |
|                 | Explanation of safety instructions .....  | 7                |                                       | General information on baking, roasting |                  |
|                 | Basic safety instructions.....            | 7                |                                       | and grilling .....                      | 22               |
|                 | Safety for children.....                  | 8                |                                       | How to use the electric oven .....      | 22               |
|                 | Safety when working with gas .....        | 8                |                                       | Operating modes.....                    | 23               |
|                 | Safety when working with electricity..... | 10               |                                       | How to operate the oven timer .....     | 24               |
|                 | Intended use.....                         | 10               |                                       | Cooking times table .....               | 25               |
|                 | Disposal .....                            | 10               |                                       | How to operate the grill .....          | 26               |
|                 | Packaging material .....                  | 10               |                                       | Cooking times table for grilling .....  | 26               |
|                 | Old equipment .....                       | 10               |                                       | How to use the alarm clock .....        | 27               |
|                 | Future transportation .....               | 10               | <b><u>7</u></b>                       | <b><u>Maintenance and Care</u></b>      | <b><u>28</u></b> |
| <b><u>3</u></b> | <b><u>Installation</u></b>                | <b><u>12</u></b> |                                       | General information .....               | 28               |
|                 | Before installation .....                 | 12               |                                       | How to clean the hob.....               | 28               |
|                 | Installation and connection.....          | 13               |                                       | Cleaning the control panel.....         | 28               |
|                 | Gas conversion.....                       | 16               |                                       | Cleaning the oven .....                 | 28               |
| <b><u>4</u></b> | <b><u>Preparation</u></b>                 | <b><u>18</u></b> |                                       | Removal of oven door.....               | 29               |
|                 | Tips for saving energy .....              | 18               |                                       | Replacing the oven lamp .....           | 29               |
|                 | Initial operation .....                   | 18               | <b><u>8</u></b>                       | <b><u>Troubleshooting</u></b>           | <b><u>30</u></b> |
|                 | Setting the time.....                     | 18               |                                       |   |                  |

# 1 General information

## Overview

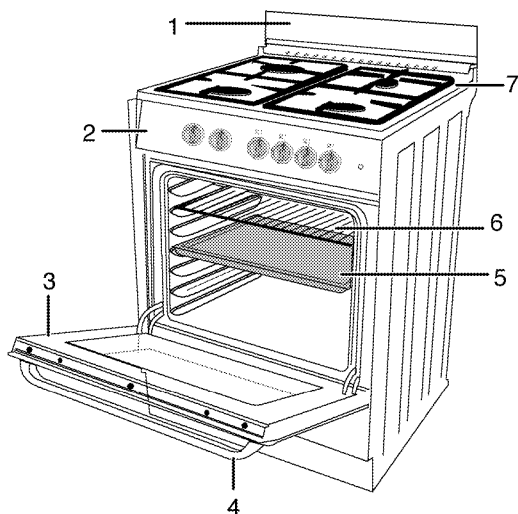

- |   |               |   |                |
|---|---------------|---|----------------|
| 1 | Splashback    | 5 | Tray           |
| 2 | Control panel | 6 | Wire shelf     |
| 3 | Front door    | 7 | Burners' plate |
| 4 | Handle        |   |                |

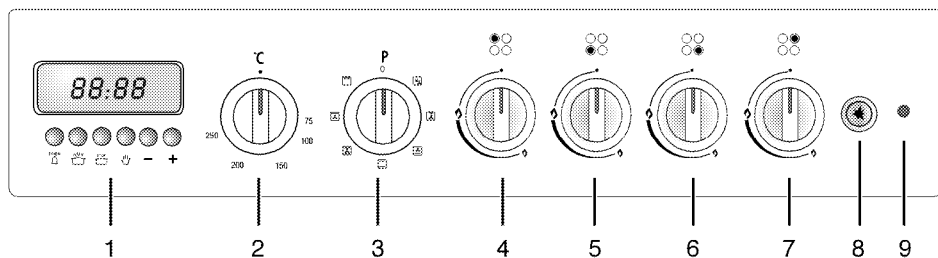

- |   |                          |   |                             |
|---|--------------------------|---|-----------------------------|
| 1 | Digital timer            | 6 | Rapid burner Front right    |
| 2 | Thermostat knob          | 7 | Auxiliary burner Rear right |
| 3 | Function knob            | 8 | Ignition button             |
| 4 | Normal burner Rear left  | 9 | Thermostat lamp             |
| 5 | Normal burner Front left |   |                             |

## Technical Data

| <b>GENERAL</b>                               |                                  |
|--|----------------------------------|
| Outer dimensions (height/width/depth)        | 900 mm/600 mm/600 mm             |
| Voltage/frequency                            | 230-240V ~ 50 Hz                 |
| Total electric consumption                   | 2.5kW                            |
| Fuse protection                              | min. 25 A                        |
| Cable type / cross section                   | H05VV-F 3G x 1,5 mm <sup>2</sup> |
| Cable length                                 | max. 2 m                         |
| Gas type/pressure                            | Natural gas 1.0 kPa              |
| Total gas consumption                        | NG 29.6 MJ/h - LPG 28.4 MJ/h     |
| Conversion to gas type/pressure <sup>s</sup> | Propane LPG 2.75 kPa             |
| <b>HOB</b>                                   |                                  |
| <b>Burners</b>                               |                                  |
| Rear left                                    | <b>Normal burner</b>             |
| Power  | NG 7.2 MJ/h - LPG 7.2 MJ/h       |
| Front left                                   | <b>Normal burner</b>             |
| Power  | NG 7.2 MJ/h - LPG 7.2 MJ/h       |
| Front right                                  | <b>Rapid burner</b>              |
| Power  | NG 11.2 MJ/h - LPG 10.4 MJ/h     |
| Rear right                                   | <b>Auxiliary burner</b>          |
| Power  | NG 4.0 MJ/h - LPG 3.6 MJ/h       |
| <b>OVEN/GRILL</b>                            |                                  |
| Main oven                                    | <b>Multifunction oven</b>        |
| Energy efficiency class <sup>#</sup>         | C                                |
| Inside illumination                          | 15-25 W                          |
| Grill power consumption                      | 2.3 kW                           |

<sup>#</sup> Basis: In electrical ovens, the data on energy labels are in conformity with EN 50304. Values were determined under standard load and convection/hot air (if available). Heating mode with an energy efficiency rating specified by EN 50304 is determined in accordance with below priority order depending on functions (modes) availability on the product. 1- Eco fan heating, 2-Slow cooking, 3-Fan heating (hot air), 4-Top and bottom heat with convection air, 5-Top and bottom heating.

This cooker has been designed and constructed in accordance with the following codes and regulations:

- AS4551 - Approval requirements for Domestic Gas Cooking Appliances

AS / NZS 3350-1 - General requirements for Domestic Electrical Appliances  
 AS / NZS 3350-26 - Particular Requirements for Domestic Electrical Cooking Appliances  
 AS / NZS 1044 - Electromagnetic Compatible Requirements.

## Accessories supplied with the unit



### Important

Accessories supplied can vary depending on the product model. All the accessories described in the user manual may not exist on your product.

### Baking tray

Can be used for pastries, frozen foods and big roasts.

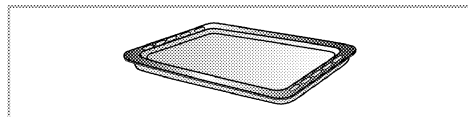

### Aluminium pastry tray

It is recommended for pastries such as cookies and biscuits.

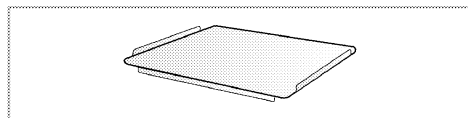

### Wire shelf

Can be used for roasting and as deposit for baking, roasting and casserole dishes.

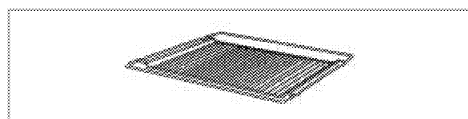

### Wire shelf

Can be used for roasting and as deposit for baking, roasting and casserole dishes.

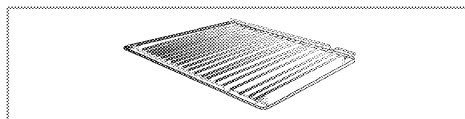

### Splash back assembly

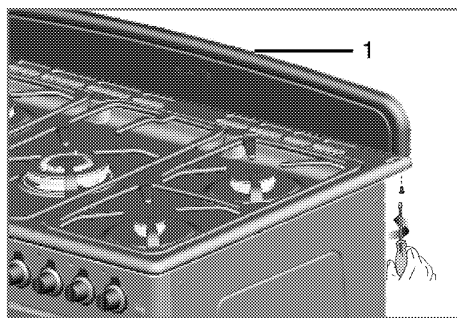

- 1 Splashback
- Remove the splash back from the packaging taking care to retain the two nuts and bolts required for fixing the splash back to the hob. Position the splash back as shown. Secure the splash back to the hob with the nuts and bolts provided. Do not over tighten the screws as damage to the hob or splash back could occur.

## Injector Table

| Position hob zone | 2 kW      | 2 kW       | 2.9 kW      | 1 kW       |
|-------------------|-----------|------------|-------------|------------|
|                   | Rear left | Front left | Front right | Rear right |
| Gas type          |           |            |             |            |
| Natural gas       | 125       | 125        | 155         | 90         |
| Propane LPG       | 72        | 72         | 87          | 50         |

## 2 Safety Instructions

---

### Explanation of safety instructions

The following types of safety instructions and information are used in this manual. They can be distinguished by the symbol and the initial signal word.

---



#### **DANGER**

##### **High risk of personal injury.**

Non-observance may or will cause serious injuries or death.

---



#### **CAUTION**

##### **Risk of personal injury.**

Non-observance may or will cause minor or medium injuries.

---



#### **NOTICE**

##### **Risk of material damage.**

Non-observance may or will cause damage on the appliance or other objects.

---



#### **Important**

##### **Tip for the user.**

Useful information on how to use the appliance. No injury risk information.

---

### Basic safety instructions

- The manufacturer reserves its right to make changes in the technical specifications in order to improve the appliance quality without any prior notice. Figures included in this manual are for schematic purpose only and may not match exactly with your appliance. Values stated on the markings of the appliance or in other printed

documents supplied with the appliance are obtained under laboratory conditions as per relevant standards. These values may vary according to the usage of the appliance and ambient conditions.

- This appliance is not intended for use by persons (including children) with reduced physical, sensory or mental capabilities, or lack of experience and knowledge, unless they have been given supervision or instruction concerning use of appliance by a person responsible for their safety. Children should be supervised to ensure that they do not play with the appliance.
- "An additional protective means to avoid contact with the oven door is available. This part should be fitted when young children are likely to be present."
- Never use when judgement or coordination is impaired by the use of alcohol and/or drugs.
- Do not operate the appliance if it is defective or shows any visible damage.
- Do not carry out any repairs or modifications on the appliance. However, you may remedy some malfunctions; see *Troubleshooting*, page 30.
- Be careful when using alcoholic drinks in your dishes. Alcohol evaporates in high temperatures and may catch fire when it comes in contact with hot surfaces.

- Do not heat closed food containers and glass jars. Pressure that may build-up in the jar can cause it to burst.
- Ensure that no flammable materials are adjacent to the appliance as the sides become hot during use.
- Do not leave empty pots or pans on plates that are switched on. They may get damaged.
- Since it may be hot, do not leave plastic or aluminum dishes on the surface of appliance. These kind of dishes should not be used to keep food either.
- Do not place baking trays, dishes or aluminium foil directly onto the bottom of the oven. The heat accumulation might damage the bottom of the oven. Keep all ventilation slots clear of obstructions.
- Appliance may be hot when it is in use. Never touch the hot burners, inner sections of the oven, heating elements etc. Keep children away!
- Always use heat-resistant gloves when putting or removing the dishes into/from your oven.
- Don't use the cooker with front door glass removed.
- Rear surface of the oven gets hot when it is in use. Gas / Electric connection should not touch the rear surface, otherwise the mains cable may get damaged. Do not trap the mains cable between the hot oven door and frame. Do not route the mains cable over the hot cooking section. Otherwise, cable insulation may melt and cause fire as a result of short circuit.

- Check all controls on the appliance are switched off after use.



### Important

For the warranty to be valid, the appliance must be installed by a qualified person in accordance with current regulations.

---

### Safety for children

- Accessible parts of the appliance will become hot whilst the appliance is in use and until the appliance has cooled, children should be kept away.
- Accessible parts may be hot when the grill is in use. Young children should be kept away.
- Do not store any items above the appliance that children may reach.
- The packaging materials will be dangerous for children. Keep the packaging materials away from children. Please dispose of all parts of the packaging according to environmental standards.
- When the door is open, do **not** load any heavy object on it and do **not** allow children to sit on it. It may overturn or door hinges may get damaged.

### Safety when working with gas

- Any works on gas equipment and systems may only be carried out by authorised qualified persons who are Gas Safe registered.
- "Prior to the installation, ensure that the local distribution conditions (nature of the gas and gas pressure) and the adjustment of the appliance are compatible."
- "This appliance is not connected to a combustion products

evacuation device. It shall be installed and connected in accordance with current installation regulations. Particular attention shall be given to the relevant requirements regarding ventilation;" See *Before installation, page 12*

- "The use of gas cooking appliance results in the production of heat and moisture in the room in which it is installed. Ensure that the kitchen is well ventilated: keep natural ventilation holes open or install a mechanical ventilation device (mechanical extractor hood). Prolonged intensive use of the appliance may call for additional ventilation, for example increasing the level of the mechanical ventilation where present."
- Gas appliances and systems must be regularly checked for proper functioning. Please arrange for annual maintenance.
- Clean the gas burners regularly. The flames should be blue and burn evenly.
- Good combustion is required in gas appliances. In case of incomplete combustion, carbon monoxide (CO) might develop. Carbon monoxide is a colourless, odourless and very toxic gas, which has a lethal effect even in very small doses.
- Request information about gas emergency telephone numbers and safety measures in case of gas smell from you local gas provider.

- Do not use or store flammable materials in the appliance storage drawer or near this appliance.
- Do not spray aerosols in the vicinity of this appliance while it is in operation. Do not modify this appliance.
- Where this appliance is installed in marine craft or in caravans, it shall not be used as a space heater
- Not suitable for use in marine craft, caravans or mobile homes, unless each burner is fitted with a flame safeguard.

---

### What to do when you smell gas

---



#### **DANGER**

#### **Risk of explosion and poisoning!**

Put out all naked flames and do not smoke, strike matches or do anything that could cause ignition. Do not operate any electric switches (e.g. light switch, TV, computer, cooker or door bell). Do not use a telephone or mobile phone.

---

1. Turn off all valves on gas appliances and gas meter at the main control valve, unless it's in a confined space or cellar.
2. Open doors and windows.
3. Check all tubes and connections for tightness. If you still smell gas leave the property.
4. Warn the neighbours.
5. Call the fire-brigade. Use a telephone outside the house.
  - 5.1 If you have door or gates that are secured by an electric lock, or entry phone, please open these manually.
6. Do not re-enter the property until you are told it is safe to do so.

## Safety when working with electricity

- Any work on electric equipment and systems may only be carried out by authorized qualified persons.
- In case of any damage, switch off the appliance and disconnect it from the mains supply by removing the fuse or switching off the circuit breaker.
- Ensure that the fuse rating is correct.

## Intended use

The appliance is designed for domestic use only. Commercial use is not admissible.

This appliance should not be used for warming the plates under the grill, hanging towels and dish cloths etc. on the handles, drying and for heating purposes.

This product should not be used for heating purposes.

The manufacturer shall not be liable for any damage caused by improper use or handling errors.

The appliance can be used for defrosting, baking, roasting and grilling food.

## Disposal

### Packaging material



#### **DANGER**

#### **Risk of suffocation by the packaging materials!**

Keep children away from the packaging materials.

The packaging material and transport locks are made from materials that are not harmful to the environment. Please dispose of all parts of the packaging

according to environmental standards. This is beneficial to the environment.

## Old equipment



This appliance bears the selective sorting symbol for waste electrical and electronic equipment (WEEE). This means that this appliance must be handled pursuant to European Directive 2002/96/EC in order to be recycled or dismantled to minimize its impact on the environment. For further information, please contact your local or regional authorities.

Electronic appliances not included in the selective sorting process are potentially dangerous for the environment and human health due to the presence of hazardous substances.

## Future transportation



#### **NOTICE**

Do not place other items on the top of the appliance. The appliance must be transported upright.

Store the appliance's original box and transport the appliance in its original carton. Follow the guidance marks that are printed on the carton.



#### **Important**

Verify the general appearance of your equipment by identifying possible damage during the transportation.

Secure the caps and pan supports with adhesive tape.

To prevent the wire shelf and tray inside the oven from damaging the oven door, place a strip of cardboard onto the inside of the oven door that lines up with the position of the trays. Tape the oven door to the side walls.

**If you do not have the original carton**

Pack the appliance in bubble wrap or thick cardboard and tape it securely in

order to prevent damage during transportation.

### 3 Installation

#### Before installation

To ensure that critical air gaps are maintained under the appliance, we recommend that this appliance is mounted on a solid base and that the feet do not sink into any carpet or soft flooring.

The kitchen floor must be able to carry the weight of the appliance plus the additional weight of cookware and bakeware and food.

Installation clearances and protection of combustible surfaces shall comply with the current (AS 5601) gas installations code. Installation shall comply with the dimension in figure bearing in mind that.

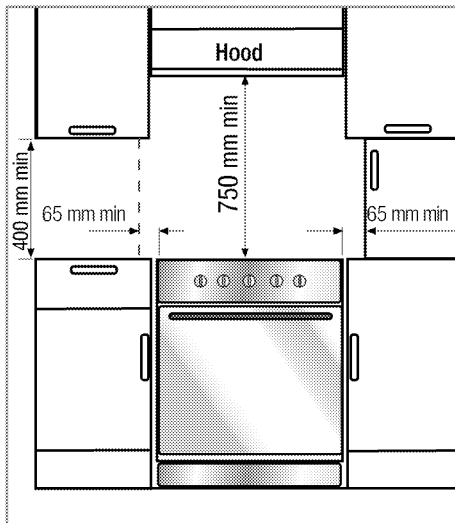

A safety distance must be left between the appliance and the kitchen walls and furniture. See figure (values in mm).

- It can be used with cabinets on either side but in order to have a

minimum distance of 400mm above hotplate level allow a side clearance of 65mm between the appliance and any wall, partition or tall cupboard.

- It can also be used in a free standing position. Allow a minimum distance of 750mm from the hob surface to adjacent surfaces above the hob surface and 600mm to a cabinet above.
- If a appliance hood is to be fitted, refer to the manufacturer's instructions regarding fixing height.
- **Gas inlet:** Rear left hand side 150mm from the top and 50mm from the left towards the centre.
- **Electric inlet:** Rear left hand side 560mm from the top and 110mm from the left towards the centre.
- The appliance corresponds to device class 1, i.e. it may be placed with the rear and **one** side to kitchen walls, kitchen furniture or equipment of any size. The kitchen furniture or equipment on the **other** side may only be of the same size or smaller.
- Any kitchen furniture next to the appliance must be heat-resistant (100 °C min.).

**Clearances from combustible material**  
**Overhead 750 mm**  
**Rear wall 50 mm**  
**Side wall 200 mm**

## Stability Chain

The cooker must be secured by both security chains at either side of the appliance to the rear wall or partition behind the cooker, as illustrated and described below.

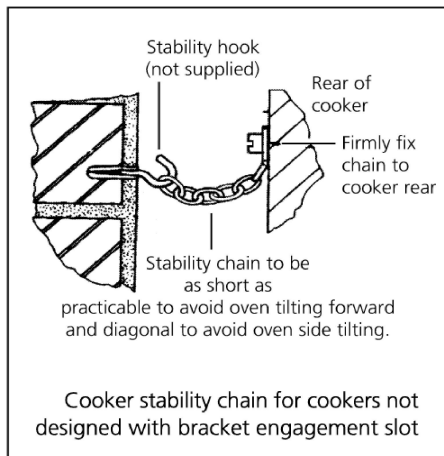

## Australia

Appliance to be installed in accordance with the local authority requirements for gas, electricity and any other authority having jurisdiction

## Room ventilation

The air for combustion is taken from the room air and the exhaust gases are emitted directly into the room.

Good room ventilation is essential for safe operation of your appliance. If there is no window or door available for room ventilation, an extra ventilation must be installed.

Do not install this appliance in a room below ground level unless it is open to ground level on at least one side.

Failure to install correctly is dangerous and could result in prosecution.

Prolonged intensive use of the appliance may call for additional ventilation, for example the opening of a window, or the use of permanent fixed mechanical ventilation system, for example, an extractor fan or cooker hood that ventilates to the outside.

| Room size                             | Ventilation opening      |
|---------------------------------------|--------------------------|
| smaller than 5 m <sup>3</sup>         | min. 100 cm <sup>2</sup> |
| 5 m <sup>3</sup> to 10 m <sup>3</sup> | min. 50 cm <sup>2</sup>  |
| greater than 10 m <sup>3</sup>        | not required             |
| In the cellar or basement             | min. 65 cm <sup>2</sup>  |

## Installation and connection



### Important

Do not install the appliance next to refrigerators or freezers. The heat emitted by the appliance will lead to an increased energy consumption of cooling appliances.

- For installation the appliance must be connected in accordance with all local gas and/or electrical regulations.
- Carry the appliance with at least two persons.



### NOTICE

Material damage!

The door and/or handle must not be used for lifting or moving the appliance.

- The appliance must be placed directly on the floor. It must not be placed onto a base or a pedestal.

## Connection to the gas supply



### DANGER

#### Risk of explosion or poisoning by unprofessional installation.

The appliance may be connected to the gas distribution system only by an authorized qualified person who is Gas Safe registered.



### DANGER

#### Risk of explosion!

Before starting any work on the gas installation, please shut off the gas supply.

- "The adjustment conditions for this appliance are stated on the label (or data plate)."
- This product is suitable for connection with an AGA approved hose assembly.

### Suitable for Flexible Hose Connection

Connection hose must comply to **AS1869 class B** 10mm diameter & be **AGA** certified length of hose is to be as short as possible hose length must not exceed 1.2m the hose must not be kinked or be able to touch any hot surface when installed.

## Gas connection for LPG- Propane Gas- 2.75 kPa



### NOTICE

Your appliance is adjusted for LP gas.

Appliance should be connected using an isolation valve and union(regulator not required).

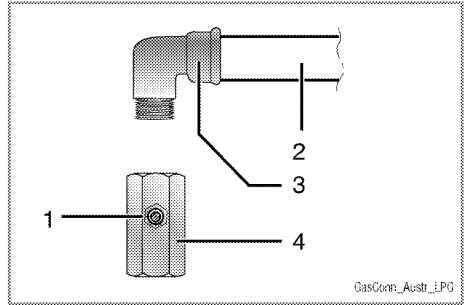

- 1 Test point
- 2 Test point adaptor
- 3 Elbow
- 4 Gas inlet pipe

## Gas connection for Natural Gas- 1.0 kPa



### NOTICE

Your appliance is adjusted for Natural gas.

Appliance should be connected using an isolation valve, union and regulator.

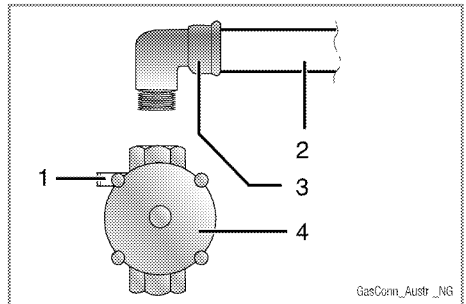

- 1 Test point
- 2 Gas regulator
- 3 Elbow
- 4 Gas inlet pipe

### Connecting with hose assembly

Where a hose assembly is to be used for the gas connection to this appliance it must :

- Comply to AS1869 Class B 10 mm diameter, be AGA gas.
- Be as short as possible, but in no case longer than 1.2 m.
- This appliance is suitable for installation with a hose assembly.
- The hose must not be able to touch any hot surface or be kinked when the appliance is installed.
- At the completion of the installation, test for leaks.



### Important

Do not use Naked Flame to test for leaks.

To ensure correct operation of the appliance it is necessary to set the correct pressure for the appliance **1.0kPa for Natural Gas** and **2.75 kPa for LPG (Propane)**.

Check the pressure by connecting the pressure gauge or manometer to test point as shown on adjacent figures. Set pressure with 2-3 burners operating on high.

Check for correct operation of burners, ignition system etc and demonstrate operation of appliance to customer. If burner low setting requires adjustment refer to conversion procedure for adjustment.



### DANGER

#### Risk of explosion and poisoning!

Put out all naked flames and do not smoke, strike matches or do anything that could cause ignition. Do not operate any electric switches (e.g. light switch, TV, computer, cooker or door bell). Do not use a telephone or mobile phone.



### DANGER

#### Risk of explosion by damage of the safety tube!

The safety tube must not be clamped, bent or trapped or come into contact with hot parts of the appliance.

## Connection to the mains supply



### Important

#### This appliance must be earthed!

Our company shall not be held responsible for any damage caused by using the appliance without earthed socket.



### DANGER

#### Risk of electric shock, short circuit or fire by unprofessional installation!

The appliance may be connected to the mains supply only by an authorized qualified person and the appliance is only guaranteed after correct installation.



### DANGER

#### Risk of electric shock, short circuit or fire by damage of the mains lead!

The mains lead must not be clamped, bent or trapped or come into contact with hot parts of the appliance. If the mains lead is damaged, it must be replaced by a qualified electrician.

The mains supply data must correspond to the data specified on the rating plate of the appliance. The rating plate is either seen when the door or the lower cover is opened or it

is located at the rear wall of the appliance depending on the appliance type.

The supply cable of the appliance must correspond to the specifications; see technical data table *Technical Data*, page 5.



### Important

The plug should be easily accessible after installation (but not above the hob).

Plug the mains lead into the socket.



### DANGER

#### Risk of electric shock!

Before starting any work on the electrical installation, please disconnect the appliance from the mains supply.

- Position appliance up to the kitchen wall.
- Securely attach safety chain to the wall behind the cooker.
- To align the appliance with the worktop, adjust the feet turning right or left hand as required.

### Final check

1. Check electrical functions.
2. Turn on gas supply.
3. Check gas installations for secure fitting and tightness.
4. Ignite burners and check appearance of the flame.



### Important

The flames should be blue and burn smoothly. If the flames appear yellowish, check secure position of the burner cap or clean the burner. Switch off gas and let burner cool before touching it.

## Gas conversion



### DANGER

#### Risk of explosion!

Before starting any work on the gas installation, please shut off the gas supply.

In order to change your appliance's gas type, change all injectors and make flame adjustment for all valves at reduced flow rate position.

### Exchange injector for the burners

1. Take off burner cap and burner body.
2. Unscrew injectors.
3. Fit new injectors.
4. Check all connections for secure fitting and tightness.



### NOTICE

New injectors have their position marked on their packing or injector table on *Injector Table*, page 6 can be referred to.

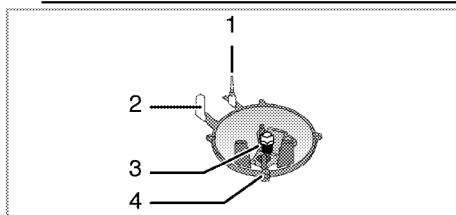

- 1 Flame failure device (model dependant)
- 2 Sparking plug
- 3 Injector
- 4 Burner



### Important

Unless there is an abnormal condition, do not attempt to remove the gas burner taps. You must call an Authorised service agent if it is necessary to change the taps.

### Reduced gas flow rate setting for hob taps

1. Ignite the burner that is to be adjusted and turn the knob to the reduced position.
2. Remove the knob from the gas tap.
3. Use an appropriately sized screwdriver to adjust the flow rate adjustment screw.

For LPG (Butane - Propane) turn the screw clockwise.

For the natural gas, you should turn the screw **counter-clockwise** once.

» The normal length of a straight flame in the reduced position should be 6-7 mm.

4. If the flame is higher than the desired position, turn the screw clockwise. If it is smaller turn anticlockwise.
5. For the last control, bring the burner both to high-flame and reduced positions and check whether the flame is on or off.

Depending on the type of gas tap used in your appliance the adjustment screw position may vary.

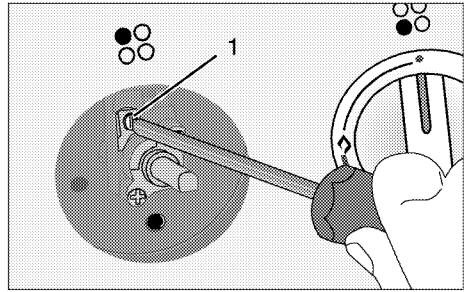

1 Flow rate adjustment screw

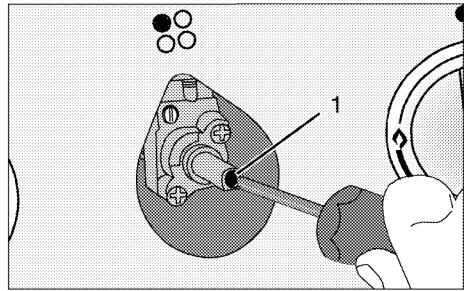

1 Flow rate adjustment screw



### NOTICE

If the gas type of the unit is changed, then the rating plate that shows the gas type of the unit must also be changed.

## 4 Preparation

### Tips for saving energy

The following tips will help you to use your appliance in an ecological way and to save energy:

- Use dark coloured and enamel coated trays, since the heat transmission will be better.
- While cooking your meals, perform a preheating operation if it is advised in the user manual or cooking instructions.
- During cooking, do not open the oven door frequently.
- Try to cook more than one type of meal within the oven at the same time (You can cook two different meals at the same time by locating cooking bowls on the same shelf). It will be suitable to cook more than one meal after each other. The oven will already be hot.
- Defrost frozen meals before cooking them.
- You can save energy by switching off your oven a few minutes before the end of the cooking time (The oven door should not be opened).
- Use pots/pans with lids for cooking. Without a lid, the energy consumption may be up to four times higher.
- Choose the burner/plate which is suitable to the saucepan base. Always choose the correct size of saucepans for your meals. For larger burners/plates more energy is needed.

### Initial operation

#### Setting the time



#### Important

Before using the oven the clock time must be set. If the clock time is not set, the main oven will not work.

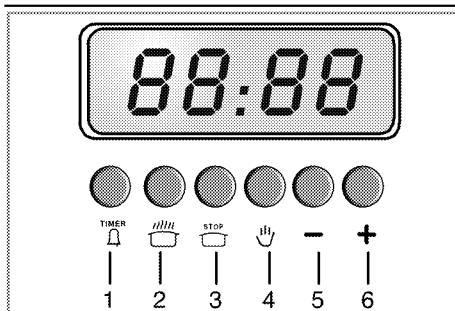

Keys for:

- 1 Alarm clock
- 2 Cooking time
- 3 End of cooking time
- 4 Switch on automatic

Keys for time adjustment:

- 5 Minus key
  - 6 Plus key
1. Keep key 1 and key 2 pressed.
  2. Set clock with key 5 or key 6. By pressing the key shortly, you advance or reset the clock by one minute. When you keep the individual key pressed, the minutes are advanced or reset quickly.
  3. Release key 1 and key 2.

## First cleaning of the appliance

---



### NOTICE

The surface may get damaged by some detergents or cleaning materials.

Do not use aggressive detergents, cleaning powder/cream or any sharp objects.

---

1. Remove all packaging materials.
2. Wipe the surfaces of the appliance with a damp cloth or sponge and dry with a cloth.

## Initial heating

---



### WARNING

#### Hot surfaces may cause burns!

Do not touch the hot surfaces of the appliance. Use oven gloves. Keep children away from the appliance.

---



### Important

Smell and smoke may emit during first heating. Ensure that the room is well ventilated.

---

Any production residues or conservation layers must be burnt off before the first use. Heat up the

appliance for about 30 minutes and then switch it off.

## Electric oven

1. Take all baking trays and racks from the oven.
2. Close oven door.
3. Select top and bottom heat with the function knob.
4. Select the highest temperature with the thermostat knob; see *How to use the electric oven, page 22*.
5. Heat approximately 30 minutes.
6. Switch off oven; see *How to use the electric oven, page 22*

## Grill oven

1. Take all baking trays and wire shelf from the oven.
2. Close oven door.
3. Select highest power of the grill; see *How to operate the grill, page 26*.
4. Heat approximately 30 minutes.
5. Switch off grill; see *How to operate the grill, page 26*

## 5 How to use the hob

### General information on cooking



#### **DANGER**

#### **Risk of fire by overheated oil!**

When you heat oil, do not leave it unattended.

**Never try to extinguish the fire with water!** When oil has caught fire, immediately cover the pot or pan with a lid. Switch off the hob if safe to do so and phone the fire service.

- Ensure handles of pans cannot accidentally be caught or knocked and do not get hot by adjacent heating zones. Avoid pans that are unstable and easily tipped. Pans that are too heavy to move easily when filled can also be a hazard. Only use flat bottomed pots or pans.
- Use pans which have sufficient capacity for the amount of food being cooked so they don't boil over and cause unnecessary cleaning.  
Do not place lids on the burners. Always position pans centrally over the burners. When transferring pans from one burner to another always lift the pans do not slide them.

### Cooking with gas

- The size of the pan and the size of the gas flame should match each other. Adjust the gas flames so that they do not go beyond the bottom of the pan always place

the pan onto the pan support in a central position.

### How to use hobs

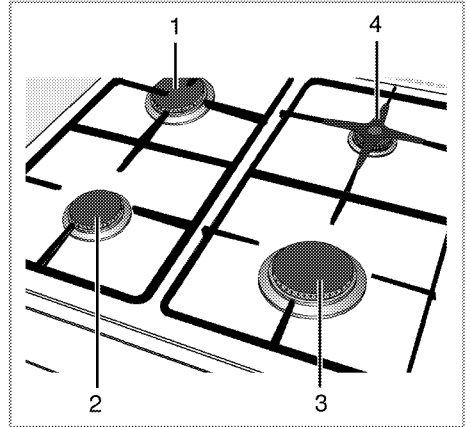

- 1 Normal burner 18-20 cm
- 2 Normal burner 18-20 cm
- 3 Rapid burner 22-24 cm
- 4 Auxiliary burner 12-18 cm is list of advised diameter of pots to be used on related burners.

The large flame symbol corresponds to the highest cooking power, the small flame symbol corresponds to the lowest cooking power. In the off position (top) the gas supply to the burner is turned off.

### Ignite the gas burners



The gas burners are ignited by means of the ignition button.

1. Keep hob control knob pressed.
2. Turn anticlockwise to the large flame symbol.

3. Press ignition button and release it again. Repeat the process until the emanating gas is lit.
4. Adjust to the desired cooking power.

### Switch off the gas burners

Turn burner control knob to off position (top).

### Flame failure device (model dependant)

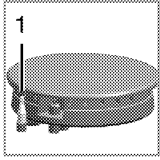

1 . Flame failure device

In case of any flame failure for any reasons in the top burners, the flame failure device immediately cuts off the gas flow.

- Turn the knob clockwise direction by pressing and wait for its ignition.
- Keep the knob at pressed position for 3-5 seconds after you see the flame around the burner.
- Repeat the sequence of operations if the flame does not ignite. After you release the knob, if the ignition does not continue repeat the same process by keeping the knob pressed for 15 seconds.



---

### DANGER

#### Risk of deflagration incase of unburned gas!

Do not press the knob for longer than 15 seconds if there was no ignition.  
Wait for one minute and then repeat the ignition process.

---

## 6 How to Operate the Oven

---

### General information on baking, roasting and grilling

---



#### **DANGER**

#### **Risk of scalding by hot steam!**

Take care when opening the oven door as steam may escape.

---

#### **Tips for baking**

- Use non-stick coated appropriate metal plates or aluminum containers or heat-resistant silicone moulds.
- Make best use of the space on the rack.
- It is recommended to place the baking mould in the middle of the rack.
- Select the correct shelf position before turning the oven or grill on - don't move oven shelves when hot.
- Keep the oven door closed..

#### **Tips for roasting**

- Seasoning with lemon juice and black pepper will improve the cooking performance when cooking a whole chicken, turkey or a large piece of meat.
- Meat with bones takes about 15 to 30 minutes longer before it is cooked than a roast of the same size without bones.
- You should calculate about 4 to 5 minutes cooking time per centimeter height of the meat.
- Let meat rest in the oven for about 10 minutes after the cooking time. The juice is better distributed all over the roast and does not run out when the meat is cut.

- Fish in a fire-resistant dish should be placed on the rack at the medium or lower level.

#### **Tips for grilling**

Grilling is ideal for cooking meat, fish and poultry and will achieve a nice brown sur-face without it drying out to much. Flat pieces, meat skewers and sausages are particularly suited for grilling as are vegetables with a high water content such as tomatoes and onions.

- Distribute the pieces to be grilled on the wire shelf.
  - If the grilling is on the wire shelf, locate a dripping pan under it in order to collect the fat.
  - Add some water in the dripping pan for easy cleaning.
- 



#### **NOTICE**

#### **Fire danger due to food which is unsuitable for grilling!**

Only use food for grilling which is suitable for intensive grilling heat. Do not place the food too far in the back of the grill. This is the hottest area and fat food may catch fire.

---

### How to use the electric oven

---



#### **Important**

Before using the oven the clock time must be set. If the clock time is not set, the main oven will not work.

---

## Select temperature and operating mode

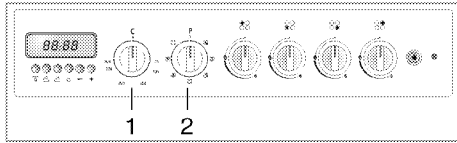

- 1 Thermostat knob
- 2 Function knob

The operating modes of the electric oven are selected with the function knob. The temperature is adjusted with the thermostat knob.

All oven functions are turned off by turning the relevant knob to off (upper) position.

1. Set thermostat knob to the desired temperature.
2. Set function knob to the required operating mode.

» The oven heats up to the adjusted temperature and maintains it. During heating, temperature lamp stays on.

### Switch off electric oven

Turn function knob and thermostat knob to off position (top).

### Operating modes

All functions for the ovens (also included main oven) are listed in this section.

The order of operating modes shown here might deviate from the arrangement on your appliance.

#### Top and bottom heat



Top and bottom heat are on. The foodstuffs are heated simultaneously from the upper and lower part. Suitable e.g. for cakes, cookies and casseroles in baking moulds. Cook with one tray only.

#### Top and bottom heat with convection air



Top and bottom heat plus fan (in the rear wall) are on. The hot air is distributed evenly and quickly all over the oven by the fan. Cook with one tray only.

#### Top heat and convection air



Top heat plus fan (in the rear wall) are on. Hot air is spread more evenly with the fan compared to only top heat.

#### Bottom heat and convection air



Bottom heat plus fan (in the rear wall) are on. Hot air is spread more evenly with the fan compared to only bottom heat.

#### Operating with fan



The oven is not heated. Only oven lamp plus fan (in the rear wall) are on. Frozen granular food is thawed slowly at room temperature and cooked food is cooled down.

#### Surface grill



The large grill (under the oven roof) is in operation. Suitable for grilling larger quantities.

- Put big or medium-sized portions in correct shelf position under the grill heater for grilling.
- Set the temperature to maximum level.
- Turn the food after half of the grilling time.

### Grill with convection air



The grill effect is not as strong as with normal grilling.

- Put small or medium-sized portions in correct shelf position under the grill heater for grilling.
- Set the temperature to maximum level.
- Turn the food after half of the grilling time.

### How to operate the oven timer

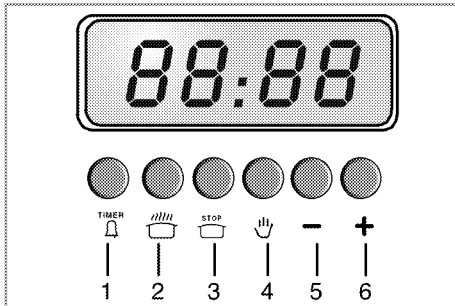

Keys for:

- 1 Alarm clock
- 2 Cooking time
- 3 End of cooking time
- 4 Switch on automatic

Keys for time adjustment:

- 5 Minus key
- 6 Plus key



### Important

The maximum time to be set for the end of the cooking process is 23 hours and 59 minutes. In case of power cut, program will be canceled. Reprogram is needed.

### Switch on fully automatic operation

In this mode of operation, you can define when the oven is to switch **on/off** automatically.

1. Keep key **3** pressed.

2. Set end of the cooking time with key **5** or key **6**. By pressing the key shortly, you advance or reset the clock by one minute. When you keep the key pressed, the minutes are advanced or reset quickly.
  - » The indication "**AUTO**" lights up on the display.
3. Release key **3**.
4. Keep key **2** pressed.
5. Set the cooking time with key **5** or key **6**. By pressing the key shortly, you advance or reset the clock by one minute. When you keep the key pressed, the minutes are advanced or reset quickly.
6. Release key **2**.
7. Put your dish into the oven.
8. Select operating mode and temperature.
  - » The oven is heated up to the set temperature and keeps this temperature until the end of the cooking time that has been selected. During the cooking process, the cooking symbol on the display is lit.
9. Press key **3** as soon as the cooking process has been completed and an alarm sounds.
10. Switch the oven off with the thermostat knob and/or the function knob.
11. Press key **4**.
  - » The indication "**AUTO**" on the display goes off.

### Switch on semi-automatic operation

In this mode of operation, you can define when the oven is to switch **off** automatically

1. Keep key **2** pressed.
2. Set the cooking time with key **5** or key **6**. By pressing the key shortly,

you advance or reset the clock by one minute. When you keep the key pressed, the minutes are advanced or reset quickly.

» The indication **"AUTO"** lights up on the display.

3. Release key **2**.

4. Put your dish into the oven.

5. Select operating mode and temperature.

» The oven is heated up to the set temperature and keeps this temperature until the end of the cooking time that has been selected. During the cooking process, the cooking symbol on the display is lit.

6. Press key **3** as soon as the cooking process has been completed and an alarm sounds.

7. Switch the oven off with the thermostat knob and/or the function knob.

8. Press key **4**.

» The indication **"AUTO"** on the display goes off.

### Important

When you press key **2** during the cooking process, the display will show the remaining cooking time for a short moment.

### Interrupting the cooking process

1. Keep key **2** pressed.

2. Keep key **5** pressed until **"0.00"** is shown as remaining cooking time on the display.

3. Release key **2**.

4. Press key **4**.

» The indication **"AUTO"** on the display goes off.

5. Switch the oven off with the thermostat knob and/or the function knob.

## Cooking times table



### Important









The values indicated in the table below are data indicative. They may vary according to the type of food as well as your preferences of cooking.





## Baking and roasting



### Important

Level 1 is the **bottom** level in the oven.

| Food         | Dish                        | Insertion level   |   | Temperature (°C)  | Cooking time (min.) (approx.)   |  |
|--------------|-----------------------------|---|---|---|---|--|
|              |                             |  |  |   |  |  |
| Cake         | Bread mould<br>24 ... 26 cm | 2 ... 3   | 3   | 170 ... 180   | 25 ... 35   | 20 ... 30  |
| Ring cake    | Cake mould<br>18 ... 22 cm  | 2 ... 3   | 3   | 170 ... 180   | 35 ... 45   | 35 ... 45  |
| Cookies      | Baking tray                 | 2 ... 3   | 3   | 170 ... 190   | 25 ... 35   | 20 ... 35  |
| Flaky pastry | Baking tray                 | 2 ... 3   | 3   | 180 ... 190   | 25 ... 35   | 20 ... 25  |
| Brioche      | Baking tray                 | 2 ... 3   | 3   | 160 ... 180   | 25 ... 35   | 20 ... 25  |
| Pies         | Baking tray                 | 2 ... 3   | 3   |  200  | 40 ... 50   | 30 ... 40  |
| Yeast dough  | Roasting tray               | 2 ... 3   | 3   |  200  | 35 ... 45   | 25 ... 35  |
| Savory pies  | Baking tray                 | 3   | 3   | 180 ... 190   | 25 ... 35   | 20 ... 30  |

| Food            | Dish        | Insertion level   |   | Temperature (°C) | Cooking time (min.)<br>(approx.)  |  |
|-----------------|-------------|---|---|------------------|---|--|
|                 |             |  |  |                  |  |  |
| Choux pastry    | Baking tray | 3   | 3   | 180 ... 190      | 40 ... 50   | 35 ... 45  |
| Lasagne         | Oven dish   | 2 ... 3   | 3   | 170 ... 180      | 40 ... 50   | 30 ... 40  |
| Pizza           | Baking tray | 2 ... 3   | 3   | 200 ... 220      | 15 ... 20   | 15 ... 20  |
| Roast beef      | Baking tray | 2 ... 3   | 3   | 15 min. 250 *    | 110 ... 120   | 100 ... 110  |
| Lamb shoulder   | Baking tray | 2 ... 3   | 3   | 15 min. 250 *    | 70 ... 90   | 60 ... 75  |
| Roast chicken   | Baking tray | 2 ... 3   | 3   | 15 min. 250 *    | 60 ... 70   | 50 ... 60  |
| Turkey (5.5 kg) | Baking tray | 2 ... 3   | 3   | 25 min. 220 *    | 180 ... 240   | 150 ... 210  |
| Fish            | Baking tray | 2 ... 3   | 3   | 200              | 15 ... 25   | 15 ... 20  |

**\* then 150**

(\*\*) For preheating, set the required temperature, the thermostat lamp will

go out when the required temperature is reached.

## How to operate the grill



### Important

Before using the oven the clock time must be set. If the clock time is not set, the main oven will not work.



### WARNING

**Hot surfaces may cause burns!**  
Close oven door during grilling.

### Switch on grill

1. Set the function knob onto the grill symbol.
  2. Set grill temperature.
  3. Preheat for approximately 5 minutes, if it is necessary.
- » The thermostat lamp is switched on.

### Switch off grill

1. Turn grill control knob to off position (top).

## Cooking times table for grilling

### Grilling with electric grill

| Food           | Insertion level | Grilling time (approx.) |
|----------------|-----------------|-------------------------|
| Fish           | 4...5           | 20...25 min. #          |
| Sliced chicken | 4...5           | 15...20 min.            |
| Lamb chops     | 4...5           | 12...15 min.            |
| Roast beef     | 4...5           | 15...25 min. #          |
| Veal chops     | 4...5           | 15...25 min. #          |

# depending on thickness

## How to use the alarm clock

In addition to using the timer for cooking, it can be also used as a reminder or an alarm clock.

As soon as the defined period of time has expired, the alarm clock will emit a signal. The alarm clock has no influence on the functions of the oven.

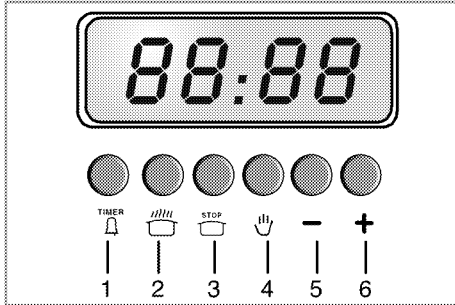

Keys for:

- 1 Alarm clock
- 2 Cooking time
- 3 End of cooking time
- 4 Switch on automatic

Keys for time adjustment:

- 5 Minus key
- 6 Plus key

### Setting the alarm clock

1. Keep key 1 pressed.



#### Important

The maximum alarm time can be 23 hours and 59 minutes.

2. With key 5 or key 6 you can set the period of time which is to elapse before the alarm signal sounds. By pressing the key once, you advance or reset the clock by one minute. When you keep the individual key pressed, the minutes are advanced or reset quickly.
  - » The alarm clock symbol on the display lights up.
3. Release key 1.



#### Important

When you press key 1 while the alarm clock is activated, the display will show the remaining cooking time for a short moment.

### Switching off the alarm

1. Keep key 3 pressed as soon as the alarm signal sounds.
  - » The alarm clock symbol on the display is extinguished.

### In order to cancel set alarm time;

1. To reset the alarm time, keep key 1 pressed.
2. Keep key 5 pressed until "0.00" is shown as remaining time on the display.
3. Release key 1.
  - » The alarm clock symbol on the display is extinguished.

# 7 Maintenance and Care

## General information



### **DANGER**

#### **Risk of electric shock!**

Switch off the electricity before cleaning appliance to avoid an electric shock.



### **DANGER**

#### **Hot surfaces may cause burns!**

Allow the appliance to cool down before you clean it.



### **NOTICE**

The surface may get damaged by some detergents or cleaning materials.

Do not use aggressive detergents, cleaning powder/cream or any sharp objects.

Clean the appliance thoroughly after each use; in this way it will be possible to remove cooking residues more easily, thus avoiding these from burning the next time the appliance is used.

No special cleaning agents are required for cleaning the appliance. It is recommended to use warm water with washing liquid, a soft cloth or sponge and use a dry cloth for drying.

**Do not use any abrasive cleaning materials!**



### **Important**

Do not use steam cleaners for cleaning.

## How to clean the hob

### **Gas hobs**

1. Remove pan supports and burner caps and clean them.
2. Clean the hob.

3. Refit burner caps and check that they are securely positioned.
4. While placing pan supports, take care that burners are centered to pan supports.

## Cleaning the control panel



### **NOTICE**

Damage of the control panel!  
Do not remove the control knobs for control panel cleaning.

Clean control panel and control knobs.

## Cleaning the oven

No oven cleaner or any other special cleaning agent is required for cleaning the oven. It is recommended to wipe the oven with a damp cloth while it is still warm.

To clean the side wall, unscrew the 4 screws on the steel rack. After cleaning operation, assemble the steel rack to the oven body again.

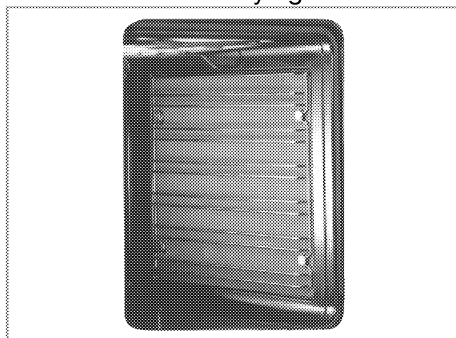

### **Catalytic walls**

Side walls or just back wall of oven interior may be covered with catalytic enamel.

The catalytic walls of the oven must not be cleaned. The porous surface of the walls is self-cleaning by absorbing and converting spitting fat (steam and carbon dioxide).

## Clean oven door

Don't use any harsh abrasive cleaners or sharp metal scrapers for cleaning the oven door. They could scratch the surface and destroy the glass.

## Removal of oven door

The oven door can be disassembled for easier cleaning of the inner space of the oven.

1. Open oven door entirely.
2. Press hinged shackles back at both sides.

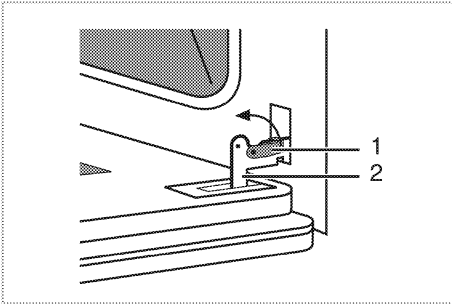

- 1 Hinged shackles
- 2 Hinge

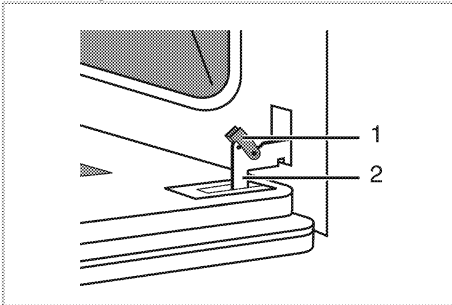

3. Put oven door in a slightly sloping position.
4. Lift the oven door to the front with both hands.

Install oven door again in reverse order after cleaning.

## Replacing the oven lamp (model dependant)



### DANGER

**Hot surfaces may cause burns!**

Make sure that the appliance is switched off and cooled down in order to avoid the risk of an electrical shock.

The oven lamp is a special heat-resisting (T 300 °C) electric light bulb; see *Technical Data*, page 5. Oven lamps can be obtained from a good local electrical store.



### NOTICE

Position of lamp may vary from diagram.

1. Switch off the appliance at the mains.
2. Unscrew glass cover by turning anti-clockwise.

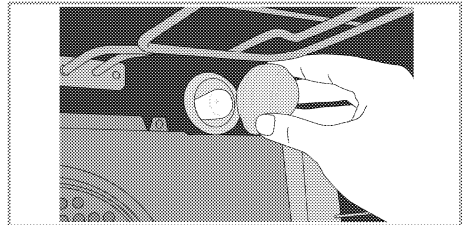

3. Unscrew oven lamp by turning anti-clockwise and replace it with new one.
4. Refit the glass cover.

## 8 Troubleshooting



### **DANGER**

**Risk of electric shock, short circuit or fire by unprofessional repairs!**

Repairs on the appliance must be carried out by an approved service centre.



### **DANGER**

**Risk of explosion or poisoning by unprofessional repair.**

Repairs on the appliance must be carried out by an approved service centre.

### **Normal operating conditions**

- Smoke and smell may emit for a couple of hours during the first operation.
- It is normal that steam escapes during operation.
- When the metal parts are heated, they may expand and cause noise.

**Before you call the service, please check the following points.**

### **Electrical equipment**

| <b>Malfunction/problem</b>   | <b>Possible cause</b>   | <b>Advice/remedy</b>  |
|------------------------------|---|---|
| The appliance does not work. | The mains fuse is defective or has tripped.                   | Check fuses in the fuse box. If necessary, replace or reset them. |
|                              | Appliance's plug can not be connected to the grounded socket. | Check the plug connection.  |
| Oven light does not work     | Oven lamp is defective.                                       | Replace oven lamp.  |
|                              | No current.   | Check fuses in the fuse box. If necessary, replace or reset them. |
| Oven does not heat.          | Function knob and/thermostat knob are not set.                | Set function knob and thermostat knob.                            |
|                              | If the appliance has a timer, the timer may not be set.       | Set the time.   |
|                              | No power.   | Check mains supply and fuse box.                                  |

## Gas

| Malfunction/problem                         | Possible cause                                      | Advice/remedy                      |
|---|---|------------------------------------|
| No ignition spark is produced.              | No electric supply to the appliance.                | Check fuses in the fuse box.       |
| No gas is emitted.                          | Main gas tap is closed.                             | Open gas tap.                      |
|   | Safety tube is bent.                                | Install safety tube without bends. |
| Burners do not burn smoothly or not at all. | Burners are dirty.                                  | Clean burner parts.                |
|   | Burners are not dry.                                | Dry burner parts.                  |
|   | Burner cap is not securely positioned.              | Position burner correctly.         |
|   | Gas tap is closed.                                  | Open gas tap.                      |
|   | Gas container is empty (in case of LPG connection). | Replace gas container.             |

### Clock/ timer (If the appliance has a digital timer)

| Malfunction/problem                              | Possible cause                    | Advice/remedy  |
|--|-----------------------------------|--|
| Clock display is blinking or clock symbol is on. | Power was interrupted previously. | Set time<br>Then switch the oven off with function knobs, set the oven function again. |

If the problem has not been solved:

1. Separate unit from the mains supply (deactivate or unscrew fuse).
2. Call the after-sales service of your store reseller.



#### Important

Do not attempt to repair the appliance yourself. There are no customer service items inside the appliance.

**Always refer servicing to an authorised service person / agency. It is recommended that the appliance be serviced at least every 2 years to ensure appliance continues to operate correctly and safely (this is not covered by warranty)**

# ELECTRICAL DISTRIBUTORS AUSTRALIA PTY LTD

ABN 11 051 297 557

SUITE 8/92A MONAVALLE ROAD (Enter of Daydream street) WARRIEWOOD  
NSW 2102

PH: 02 9999 2124 FAX: 02 9999 1684

EMAIL: EDAAUST@bigpond.com web site www.euromaid.com.au

## **EUROMAID COOKER WARRANTY IN ADDITIONS TO RIGHTS BY LAW**

Electrical Distributors Australia Pty Ltd guarantees to the original purchaser subject to model type either 12 months or Two Years of ownership that any part with defective material be replaced free of charge, provided that all service work is carried out by Electrical distributors Australia Pty Ltd or the nearest appointed service agent.

### 2 Year Warranty Products:

All built in appliances such as Ovens, Gas and Electric Cook tops.

### 1 Year Warranty Products:

All Free Standing Gas and Electric products including bench top and portable products.

Portable products ie MC110T are to be returned to the nearest service agent by the purchaser these products offer no in home warranty repair.

Where the appliance is installed outside the normal service area of Electrical Distributors Australia Pty Ltd or its Appointed Service Agent the purchaser will pay the travel cost charges for the service agent to attend the repair or to take the appliance to the service centre.

### **Built In & Free Standing Appliances:**

Access must be granted within normal working hours and our Service Agents must have easy access to these built in appliances and charges will be the responsibility of the purchaser where the service technician cannot obtain easy access to remove the appliance for inspection prior to repair.

This Warranty is not transferable and excludes any repair or replacement caused by Power Surges faulty installation abuse, Pest Damages, misuse, acts of God or accident.

The above Warranty is for Domestic Application only and is limited to Three (3) Months in Commercial Applications.

**FOR SERVICE OUTSIDE THE ABOVE AREAS PLEASE CONTACT HEAD SYDNEY OFFICE PH: 02 9999 2124**

### **AUTHORISED SERVICE AGENTS:**

#### **NSW**

ALL GENERAL WHITEGOODS  
4/11 HALLSTROM PLACE  
WETHERILL PARK 2164 NSW  
PH: 02 97561511  
FAX: 02 97561091

#### **GOLD COAST**

ROSHAD APPLIANCE SERVICE  
1/13 LEDA DRIVE  
BURLEIGH QLD 4220  
PH: 0755357044  
FAX: 0755357407

#### **QUEENSLAND**

ENDEAVOUR REFRIGERATION  
167 ROBERTSON STREET  
FORTITUDE VALLEY QLD 4006  
PH: 07 3137 3633  
FAX: 07 3137 3663

#### **VIC**

ALL STOVE SERVICE  
73 HAVERSHAM AVE  
WHEELER HILLS VIC 3150  
PH: 1800631348  
MOBILE: 0418367468

#### **TASMANIA**

FARR ELECTRICAL  
286 MAC QUARIE STREET  
SOUTH HOBART TAS 7004  
PH: 03 6223 1010  
FAX: 03 6223 7039

#### **WESTERN AUSTRALIA**

DACAP UNIT  
4/57 KENT STREET  
CANNINGTON WA 6107  
PH: 08 9358 6033 FAX: 08 9358 6044  
PERTH

#### **SOUTH AUSTRALIA**

PRESTIEGE APPLIANCE REPAIRS CENTRE  
4/65 STEPHENS AVENUE  
TORRENSVILLE SOUTH AUSTRALIA 5031  
PH: 08 83522022  
FAX: 08 83522044

EAN kodu yapıştırma yeri

### Data Label

Tip etiketi yapıştırma yeri