

D'AMANI

OWNERS MANUAL

Model - DGEUCCT900SS

**INSTRUCTIONS AND ADVICE FOR THE
INSTALLATION, USE AND MAINTENANCE OF THE
COOKER**

CE

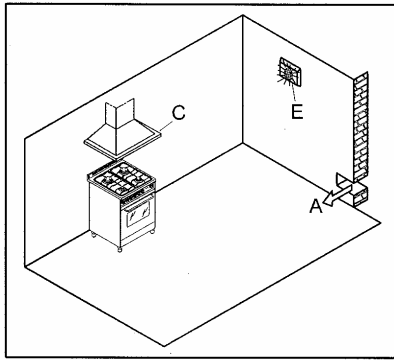

FIG. 1

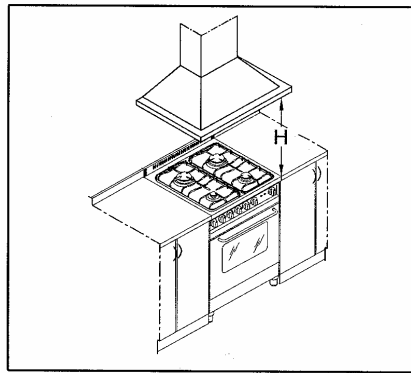

FIG. 2

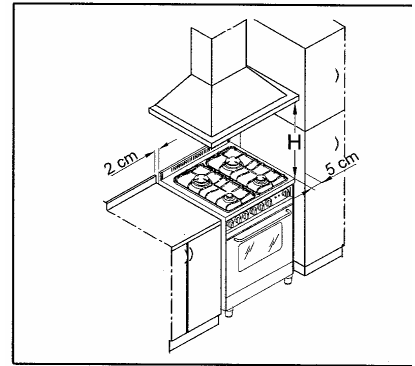

FIG. 3

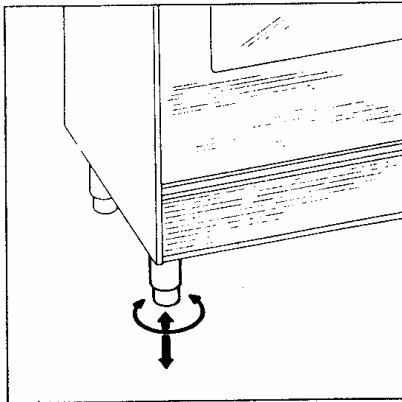

FIG. 4

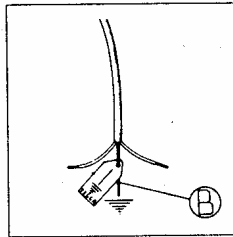

FIG. 5

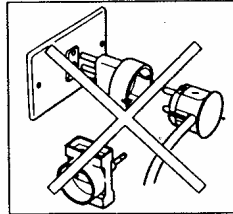

FIG. 6

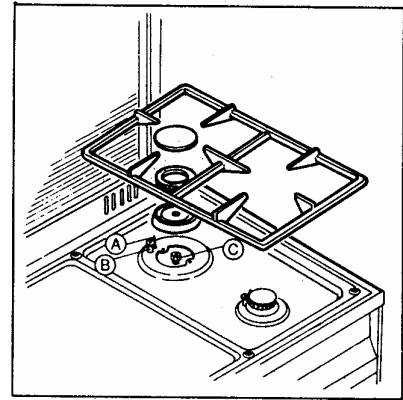

FIG. 7

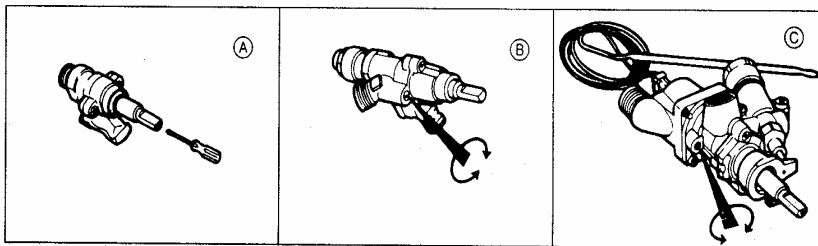

FIG. 8

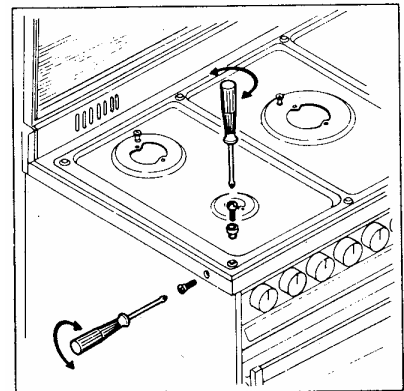

FIG. 9

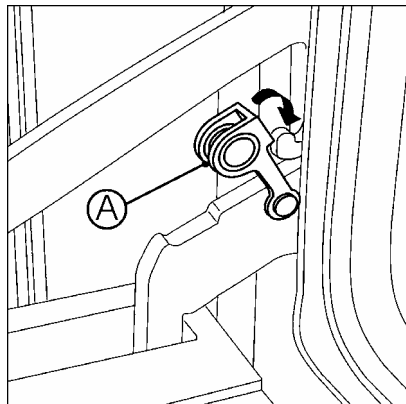

FIG. 10

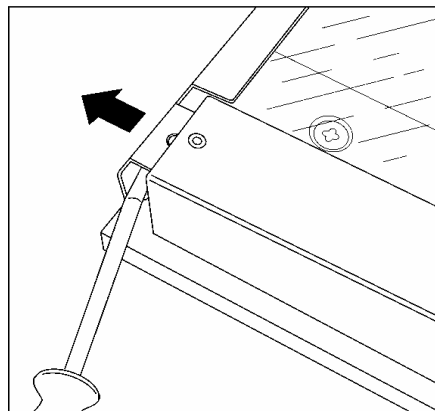

FIG. 10 A

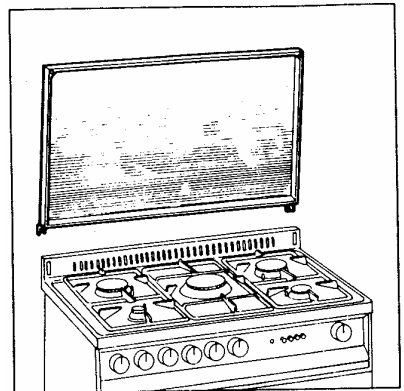

FIG. 11

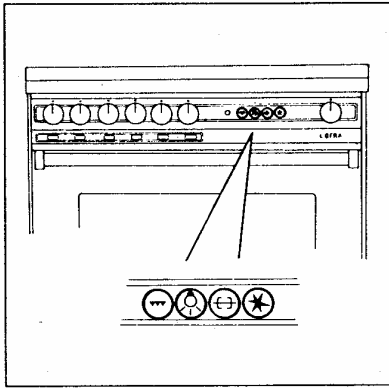

FIG. 12

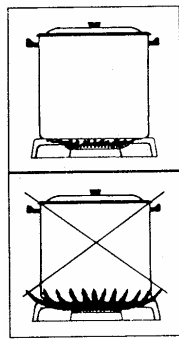

FIG. 13

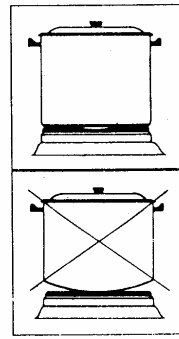

FIG. 14

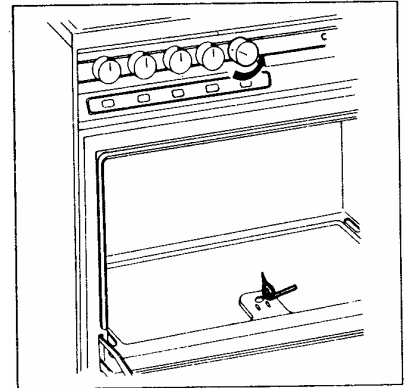

FIG. 15

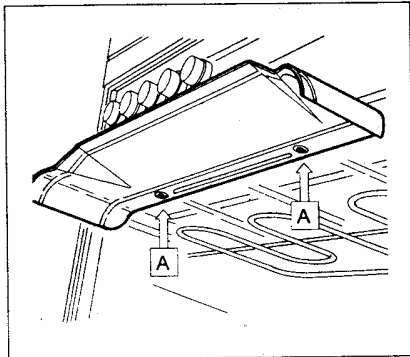

FIG. 16

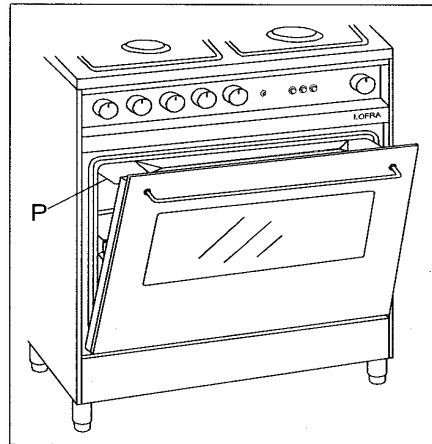

FIG. 17

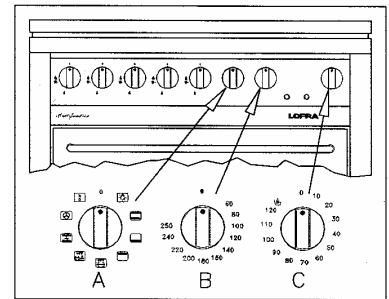

FIG. 18

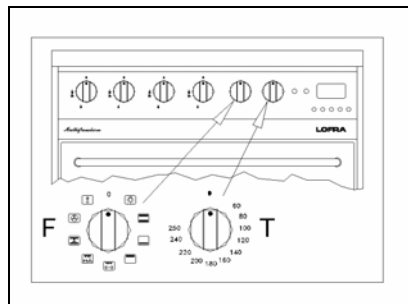

FIG. 19

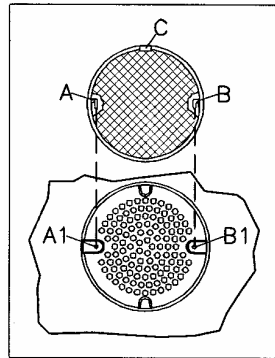

FIG. 20

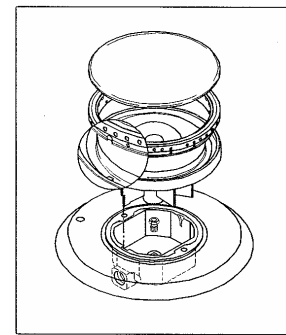

FIG. 21

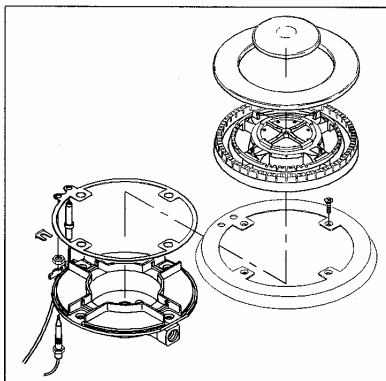

FIG. 22

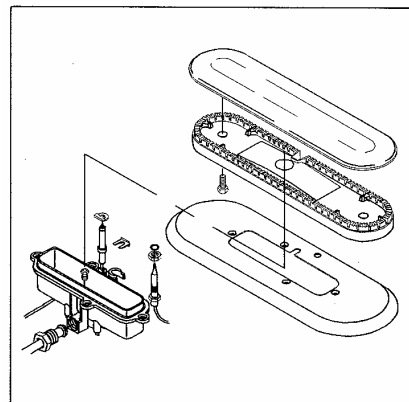

FIG. 23

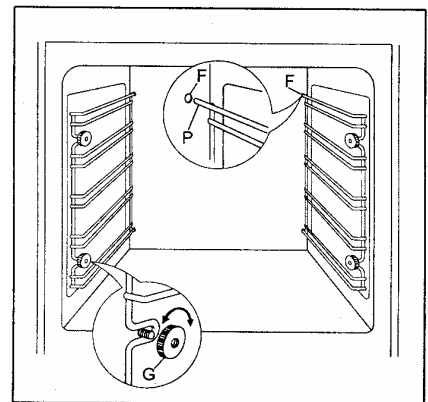

FIG. 24

Dear Customer,

We would like to thank you for having chosen a D'amani product. The traditions and seriousness of our company guarantee the technical and design quality of your choice; our production is made only from top quality materials with construction criteria able to satisfy even the most exacting customer.

For the best use of your new cooker, please read this handbook carefully, you will find all the indications and advice necessary for easy and practical use. The handbook is a sure guide for the installation, use and maintenance and, if the instructions are correctly followed, guarantees excellent working and performance of the cooker.

Once again thank you for your choice,

Yours sincerely

ALL D'AMANI COOKERS UNDERGO TESTS FOR THE SEALS OF THE GAS PIPES, SETTING THE MINIMUM AND MAXIMUM OUTPUT OF THE GAS BURNERS; TESTS TO THE ELECTRICAL SYSTEMS; EARTH CONTINUITY – DIELECTRIC RIGIDITY – INSULATION RESISTANCE – LEAKS AND ABSORPTION CURRENTS, ALL CARRIED OUT USING SPECIFIC ELECTRONIC INSTRUMENTS THAT GUARANTEE UTMOST RELIABILITY.

INDEX

Warnings and recommendations.

Page

1. Installation

Page

- 1.1 where to install the cooker
- 1.2 discharge of flue gases
- 1.3 positioning the cooker
- 1.4 connection to the gas supply
- 1.5 connection to the electricity supply
- 1.6 stabilising the cooker
- 1.7 transforming the gas to the hob burners
- 1.8 regulating the minimum output of the hob burners
- 1.9 transforming the gas to the oven burners and gas grill
- 1.10 before leaving

2. Maintenance

- 2.1 gas supply rubber pipe
- 2.2 electricity supply cable
- 2.3 access to electrical/gas components
- 2.4 replacing the thermostat taps
- 2.5 dismantling and assembling the oven door
- 2.6 replacing the light bulb
- 2.7 glass cover

3. Using the cooker

- 3.1 using the cooking hob
- 3.2 oven performance
- 3.3 using the grill
- 3.4 rotisserie
- 3.5 minute timer
- 3.6 multiple function cookers
- 3.7 cooking hob with Glass-Plate
- 3.8 fitting the fat filter on the fan cover inside the multiple function giant oven
- 3.9 fitting the gas burners to the hob
- 3.10 telescopic runners
- 3.11 wire racks
- 3.12 abnormal operation

4. Cleaning

5. Indicative cooking times and temperatures

6. Tables

7. Wiring diagrams

WARNINGS AND RECOMMENDATIONS

- ⇒ This appliance has been designed for domestic use only. DO NOT use in any other situation.
- ⇒ The adjacent cabinetry and all materials used in the installation must be able to withstand a minimum temperature rise of 85°C above ambient during periods of use. Certain types of kitchen cabinetry and finishes (especially vinyl finishes) are particularly prone to heat damage or discolouration at temperatures below the above guidelines. Please check with your kitchen manufacturer for specifications of your kitchen cabinetry and finishes.
- ⇒ These instructions are only valid for the country indicated in the identification symbols on the cover of the instruction handbook and on the appliance.
- ⇒ This appliance conforms to Community directives:
CEE 73/23 – CEE 89/336 – CEE 90/396 – CEE 93/68
- ⇒ The customer is responsible for installation.
- ⇒ All installation, adjustments, changing the gas supply and maintenance operations must be carried out by an authorised person, in accordance with the enclosed instructions and current installation standards. The manufacturer declines any responsibility due to faulty installation, setting, handling and use of the cooker.
- ⇒ Data and features regarding each model can be found on the plate located on the door of the lower storage compartment.
- ⇒ For any service repairs to the appliance, show the service engineer the guarantee and the till receipt with the date of purchase.
- ⇒ Before carrying out any maintenance or transformation operations, turn off the electricity supply and close the gas upstream from the appliance. If components and/or accessories need replacing, only exclusive D'amani originals must be used. Only qualified technicians can perform installation and maintenance operations
- ⇒ Keep the instruction handbook near the cooker, so that it can be consulted in any moment, to check on the right indications and recommendations for correct use and optimum performance.
- ⇒ Before using the cooker remove the plastic protection from the stainless steel, aluminium and/or painted parts to avoid it melting. Utmost care must be taken when removing this protection to avoid damaging the protected parts.
- ⇒ This appliance is not intended for use by young children or infirm persons unless they have been adequately supervised by a responsible person to ensure that they can use the appliance safely. Young children should be supervised to ensure they do not play with the appliance.
- ⇒ Periodically check that there are no gas leaks from the connection pipe between the cooker and the bottle or supply line; replace upon expiry.
- ⇒ When the cooker is not in use, ensure that all knobs are in the off position; furthermore, if it is unused for a period of time, turn off the bottle valve or the supply valve, and the main switch to the electricity supply.
- ⇒ If you smell gas, do not use flames or turn on electric appliances and/or switches. OPEN THE WINDOWS. Call your Service Department.
- ⇒ For the burners to work well, keep them clean together with the covers and the flame diffusers.
- ⇒ We recommend lighting the gas burners on the hob before putting the pans on the grid.
- ⇒ Before using the oven for the first time, we recommend leaving it on for one hour at the maximum temperature. During this smoke can form together with unpleasant smells caused by the glue in the heat insulation or oiled plates. To remove these, it is sufficient to aerate the room, by opening a window for example. This is quite normal.
- ⇒ Some models are fitted with an aluminium tray, ideal for baking pastries (180-200°C), as aluminium is an ideal heat conductor, does not burn the food, does not change the flavour and does not destroy the vitamins. For better use, we recommend as follows: wash the tray with warm soapy water, grease the inside with olive oil and leave to absorb for one day (this way the tray is ready for excellent use for various types of cooking). Max. load 3 kg.

- ⇒ If the lid is made of hardened glass, do not close it when the burners or electric plate are on, or still hot, as this could cause dangerous breakage.
- ⇒ Remove any objects from on top of the cover before opening it.
- ⇒ Please dispose of all packing materials in a neat and tidy way for refuse collection and, if possible, take them away for recycling.
- ⇒ WARNING – Accessible parts will become hot when in use. To avoid burns and scalds children should be kept away.
- ⇒ Do not use a steam cleaner for cleaning your appliance.
- ⇒ WARNING: In order to prevent accidental tipping of the appliance, for example by a child climbing onto the open oven door, the stabilizing means must be installed. Refer to the instructions for installation.
- ⇒ **DO NOT SPRAY AEROSOLS IN THE VICINITY OF THIS APPLIANCE WHILE IT IS IN OPERATION**
- ⇒ **DO NOT STORE OR USE FLAMMABLE LIQUIDS OR ITEMS IN THE VICINITY OF THIS APPLIANCE**
- ⇒ **WHERE THIS APPLIANCE IS INSTALLED IN A MARINE CRAFT OR IN CARAVANS, IT SHALL NOT BE USED AS A SPACE HEATER**

TECHNICAL INSTRUCTIONS

This appliance shall be installed only by authorised personnel and in accordance with the manufacturer's installation instructions, local gas fitting regulations, municipal building codes, water supply regulations, electrical wiring regulations, AS 5601/AG 601 - Gas Installations and any other statutory regulations.

The manufacturer declines any responsibility due to faulty installation, setting, handling and use of the cooker.

WARNINGS

- Before installing, ensure that the local gas distribution (nature and pressure) and electricity supply correspond with the data plate.
- The conditions for the cooker are given on the data plate fitted to the inside edge of the left hand side of the cooker.
- This cooker is not fitted to an evacuation device for the flue gases. It must therefore be installed and connected in conformity with current legislation. Special attention must be paid to ventilation requirements.

1. INSTALLATION

1.1. WHERE TO INSTALL THE COOKER

- Ventilation must be in accordance with AS5601/AG601 – Gas Installations. To guarantee correct operation, the appliance should have adequate ventilation for complete combustion of gas, proper flueing and to maintain temperature of immediate surroundings within safe limits. The cooker must be installed in location that allows access for service. ~~If the appliance is placed on a base, measures must be taken to prevent the appliance slipping from the base.~~ 

1.2. DISCHARGE OF FUEL GASES

Cooking appliances discharge flue gases, therefore we recommend installing a Rangehood above the appliance, discharging the air directly to the outside. If it is not possible to connect a hood, an electric fan can be fitted to a window or a wall (fig.1-E), which must be turned on when the cooker is on, as long as the ventilation standards are strictly adhered to.

1.3. POSITIONING THE COOKER

Any adjoining wall surface situated within 200mm from the edge of any hob burner must be a suitable non-combustible material for a height of 150mm for the entire length of the hob. Any combustible construction above the hob must be at least 650mm above the top of the burner and no construction shall be within 450mm above the top of the burner. Clearance from the side of the cooker below the hob must be 2cm. Refer to AS5601/AG601 – Gas Installations.

If the cooker has a kickboard fitted, a vent must be made in the front of 2 cm for the entire width of the cooker.

After removing the packing material, remove the plastic protection from the stainless steel and/or painted parts to avoid it melting; utmost care must be taken when removing this protection to avoid damaging the protected parts. Now the feet can be fitted (fig.4), they must be fixed to the ends of the slits of the cooker pedestal. They can be adjusted in height to line the cooker up with other units, ensure that the cooker is perfectly stable. Fit the burners, the flame diffusers and the grids in their relative housing on the hob. To avoid damaging the stainless steel hob, in the models prepared for this, fit the scratchproof rubber stoppers supplied with the cooker to the central pan grid made from chrome-plated rod.

N.B. when the burners are alight, there must not be any draughts inside the room that could interfere with their working or even blow them out.

1.4. CONNECTION TO THE GAS SUPPLY: CURRENT INSTALLATION STANDARDS

The gas inlet connection is ½'BSP and is located 40mm from the left hand side of the cooker, approximately 450mm from the base of the cooker (add the height of the adjustable leg to determine the height from the floor). For Natural Gas installations, fit the Natural Gas Regulator supplied with the cooker. For Universal LPG, fit the test point assembly supplied with the cooker.

Rigid Pipe A rigid pipe connection may be used with this appliance provided it complies with AS5601 table 3.1.

Flexible Hose This appliance is suitable for connection with a flexible hose which complies with AS/ANZ1869, 10mm internal diameter, class B or D and between 1 to 1.2m long in accordance with AS5601 high level connection. The Hose should not be subjected to abrasion, kinking or permanent deformation. The restraining chain supplied fitted to the rear of the cooker must be securely fixed to the wall (lower hook position) to prevent strain on the gas hose connections when the cooker is moved forward from the installed position. Refer to Section 1.6 below. Unions compatible with the hose fittings must be used.

The cooker is factory set for Natural gas. The test point pressure should be adjusted to 1.00kPa with one rapid burner operating at maximum. If installing for use with Universal LPG, a gas regulator suitable for a supply pressure of 2.75kPa should be part of the gas tank supply.

After connection, check that there are no gas leaks by using a specific instrument or, more simply, using soapy water.

1.5. CONNECTION TO THE ELECTRICITY SUPPLY

The cooker is supplied with plug and cable. You installer must ensure that the electrical circuit the appliance is getting connected to is suitable with the appliance. This can be checked by referring to the data plate on the cooker. All installations must be installed in by a qualified authorised person in accordance with AS/NZS3000 wiring rules. The yellow-green supply cable (fig. 5) must be connected to an efficient earth system and the plug or multiple polar switch must be easy to inspect once the cooker is installed.

IMPORTANT: no adapters must be fitted between the electric socket and the supply cable to the cooker, Fig. 6.

1.6. STABILISING COOKER

There are 2 lengths of chain fitted to both sides of the cooker at the rear. Both of these chains should be securely fixed to the wall (upper hook position) to prevent the cooker from tipping forward if a weight is placed on the oven door. After fixing the chains to the wall, check that the cooker cannot tip forward.

IMPORTANT: The chains must not have any slack, they must be taut to prevent tipping.

If the cooker is installed next to or between cupboards and there is no access to the chains, please contact D'amani on 1800 444 357.

When installing the cooker with a flexible hose connection, the chain is also fixed to the wall (lower hook position) to prevent strain being placed on the gas hose connections when the cooker is moved forward from its installed position. See section 1.4 above.

Delete or correct these diagrams.

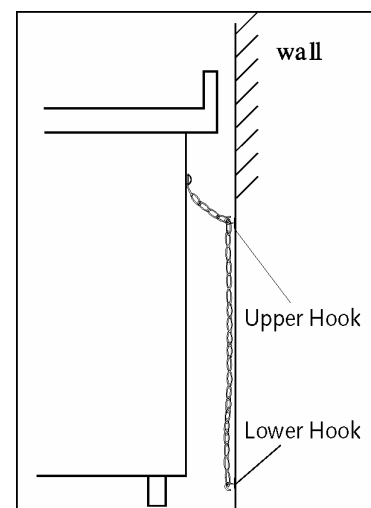
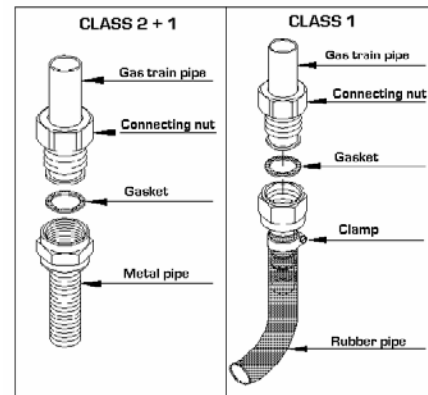

1.7. GAS CONVERSION OF THE HOB BURNERS

This cooker is suitable for use with Natural Gas or Universal LPG. When converting from one gas to another type of gas the data plate must also be replaced.

Burners: auxiliary, semi-rapid, rapid, treble crown, fish kettle. These burners are all fitted with injectors with shapes to allow a primary input of air gauged for each type of gas; therefore, air regulation is not required. For transforming from one sort of gas to another, proceed as follows: remove the grids, covers, holed flame diffuser and the burner supports (fig. 7); replace the holed injectors as indicated in 7/C depending on the type of gas used, referring to table 1; replace the burner supports, flame diffusers, covers and grids; regulate the minimum output following the instructions given in paragraph 1.7. When converting from Natural Gas to Universal LPG ensure that the NG regulator is removed and replaced with the Test Point Assembly. When converting from Universal LPG to Natural Gas, fit the Natural Gas regulator supplied with the conversion kit.

1.8. REGULATING THE MINIMUM OUTPUT OF THE HOB BURNERS

Normal/valve taps

Ignite the burners to the maximum position, remove the knob and insert a small flat screwdriver into the rod or through the holes on the side of the control dashboard, depending on the type (fig. 8 A/B). Loosen the by-pass screw by two turns in an anti-clockwise direction and rotate the rod to the minimum position. Adjust the previously loosened screws until a reduced but stable flame is acquired, even when rapid changes are made from the maximum to the minimum position with the burner cold. If there are safety taps, let the burner run on minimum for a few minutes to ensure that the device does not cut in. If it should, increase the minimum.

N.B. for LPG settings, the burner minimum must be set by screwing the tap by-pass all the way down.

1.9. GAS CONVERSION OF THE OVEN BURNERS AND GAS GRILL

This cooker is suitable for use with Natural Gas or Universal LPG. When converting from one gas to another type of gas the data plate must also be replaced.

Oven burners:

to have access to the oven injector proceed as follows:

- open the oven door and remove the oven base;
- unscrew the screw that fixes the burner inside the oven (in the giant oven it is fixed to the side wall of the muffle, and in the other models it is fixed to the tab in the front part) and remove the burner from its housing paying attention not to damage the knob fixed to it;
- replace the holed injector depending on the type of gas used, refer to table 1;
- replace the burner in its original position.

Setting the minimum for the oven thermostat

To set the minimum, proceed as follows:

- open the oven door;
- light the oven burner in the maximum position, close the door and wait for about 10 minutes (or the time required for the oven to heat up to about 230°C);
- remove the oven knob and, through the hole in the control panel, depending on the type of thermostat (Fig. 8C), unscrew the by-pass screw of the thermostat by two turns;
- replace the knob and turn it to the minimum position, remove the knob and adjust the previously loosened screws until a reduced, stable flame is acquired, even with rapid changes from maximum to minimum and rapid opening/closing of the oven door.

N.B. For LPG setting, the setting for the oven burner minimum is obtained by screwing the thermostat by-pass firmly down.

When converting from Natural Gas to Universal LPG ensure that the NG regulator is removed and replaced with the Test Point Assembly. When converting from Universal LPG to Natural Gas, fit the Natural Gas regulator supplied with the conversion kit.

1.10. BEFORE LEAVING

Check all connections for gas leaks with soap and water. DO NOT use a naked flame for detecting leaks. Ignite all burners to ensure correct operation of gas valves, burners and ignition. Turn gas taps to low flame position and observe stability of the flame. When satisfied with the hotplate, please instruct the user on the correct method of operation. In case the appliance fails to operate correctly after all checks have been carried out, refer to the authorised service provider - on Tel:1800 444 357.

2. MAINTENANCE

WARNINGS:

Before carrying out any maintenance or transformation operations, turn off the electricity supply and close the gas upstream from the appliance. If components and/or accessories need replacing, only exclusive D'amani originals must be used. Servicing should be carried out only by authorised service personnel.

2.1. FLEXIBLE HOSE GAS SUPPLY

The condition of the flexible hose gas supply pipe should be checked periodically (once a year) and replaced if there are signs of cracking, cuts, scratches or burns, or if the hose is no longer flexible but hard. If the hose is damaged, turn off the gas supply and contact your authorised service provider or call Tel:1800 444 357 for a replacement hose. (This is not covered under warranty)

2.2. ELECTRICITY SUPPLY CABLE

If the electricity supply cable needs replacing, please remember that this is an X type of connection, therefore only authorised D'AMANI technicians may effect the replace. Only use type HO5FRR-F, the earth wire (yellow/green) must be at least 2 cm. longer than the other two phase wires (fig. 5 B). This ensures that electrical safety is guaranteed should the wire accidentally be pulled.

For the cookers with gas oven and electric grill, use a HO5RR-F 3x1 mm² cable, for the cookers with electric oven and grill use a HO5RR-F 3x1.5 mm² cable with outside diameter max. 9 mm.

2.3. ACCESS TO ELECTRICAL/GAS COMPONENTS

To carry out maintenance and/or replace the electrical components fitted in the back of the cooker (e.g. light bulb holder, rotisserie, supply cable, electric ignition generator, resistances) the rear protection panel must be removed by unscrewing the screws that fix it to the sides.

To carry out maintenance and/or replace the electrical components fitted to the front panel (e.g. control panel, taps, thermostat, timer, etc), besides the rear panel you must also proceed as follows:

- in all models where fitted, remove the flue pipe;
- remove the hob grids and burners;
- unscrew the screws that fix the cups to the hob and, for models with safety device, also remove the nuts that block the thermocouples;
- unscrew the 2 front upper or front side screws (fig. 9) that fix the hob and then lift it;
- remove the knobs and remove the screws that block the gas train to the front control panel, remove the gas train taking care not to damage any pipes or thermocouples.
- to reassemble follow these instructions in reverse order.

2.4. REPLACING THE THERMOSTAT TAPS

If a tap or a thermostat needs replacing, first follow the instructions given in paragraph 2.3. (access to electrical/gas components), then remove the nut that blocks the supply pipe to the burner, the thermocouple nut and the screws that fix the tap or the thermostat to the gas train. Besides the tap or the thermostat, it is also important that the gas-sealing gasket is replaced. After maintenance, ensure that there are no leaks using a specific instrument or, more simply, soapy water.

N.B. qualified technicians must only carry out these maintenance operations.

2.5. DISMANTLING AND ASSEMBLING THE OVEN DOOR

Completely open the oven door, insert the rotation-blocking device in the hook on the hinge rods as given in Fig. 10. Grasp the door on both sides and slowly close until you feel a certain resistance, at this point simultaneously push and lift the door upwards to free it from the cooker hinge locks and then remove it.

To assemble the door follow these instructions in reverse, taking care that the hinge lock is properly fitted into its housing.

2.6. REPLACING THE LIGHT BULB

Turn the cooker off at the mains before replacing the bulb.

Open the oven door, remove the protective glass cover, replace the light bulb (attention: it must be resistant up to 300°C) and replace the glass protection.

2.7. GLASS COVER

Some models are supplied with a glass cover; to remove this it should be lifted all the way up and slid out of its housing in the shoulders of the cooker. To reassemble repeat the instructions in reverse order (fig. 11).

3. USING THE COOKER

WARNINGS:

- If the burner flames accidentally go out, turn off the taps and wait for one minute before igniting.
- Using a gas cooker produces heat and humidity in the room where it is installed. Ensure the room is well ventilated, keeping all the natural air vents open or installing an extraction hood with flue pipe.
- Intensive or extensive use of the cooker could require supplementary ventilation, for example opening a window, or more efficient ventilation by increasing the capacity of the mechanic ventilation, if fitted
- DO NOT use aluminium foil or place any baking pans or trays directly onto the base of the oven, or any enamelled surface in the cooker.

On the front control panel, there are one or two luminous signal lights depending on whether the oven runs on gas or electric. If the cooker has a gas oven a green signal lights up when an electric item is turned on (ELECTRIC PLATES, ROTISSERIE, ELECTRIC GRILL). If the cooker has an electric oven, besides the green signal light there is also a yellow light that turns on and off when the THERMOSTAT cuts in to regulate the temperature inside the oven.

3.1. USING THE COOKING HOB



Gas burners

The burners can be ignited: manually, electronically or electronically with automatic ignition incorporated in the burner tap.

Manual ignition: rotate the burner knob to be used to the maximum position, indicated by the  signal and at same time bring a piezoelectric lighter or a match close to the burner.

Two handed electronic ignition: after turning the knob to the maximum position  press the button marked with the

 symbol on the front control panel (Fig. 12).

Electronic automatic ignition incorporated in the knob: turn the knob to the maximum position   press down and the burner automatically lights up.

• no gas supply (knob turned off)

 maximum gas supply

 minimum gas supply.

To obtain minimum supply, rotate the knob in an anti-clockwise direction and point the indicator to the small flame .

Safety device: once the burner is on, keep the knob pressed for at least 5 seconds and then release it, the burner remains alight due to the thermocouple fig. 7 point A, which keeps the gas flow open through the safety valve, which shuts off the gas flow should the burner accidentally go out.

Burner performance: in correspondence with the "medium and small" burners, various pans can be used with a minimum diameter of 120 mm. The pans must not have concave or convex bottoms, but be perfectly flat as given in Fig. 14; for optimum performance of the burners uses saucepans as shown in fig. 13, i.e. sufficient diameter so that the flame does not go beyond the edge of the pan. It is also advisable, when the liquid starts boiling, to reduce the flame as far as possible, but keeping the liquid at boiling point. For safety reasons, we recommend using pans with the following diameters to use on the various burners

Auxiliary	(1000W)	120÷180 mm.
Semi-rapid	(1750W)	120÷220 mm.
Rapid	(3000W)	180÷280 mm.
Treble crown	(3900W)	240÷330 mm.
Fish kettle	(3000W)	120÷280 mm. (indicated minimum measurements)

Electric plates

The first time the plate is turned on or if it is not used for a long time, to eliminate any humidity absorbed by the insulating cover it should be turned on and left alight for 30 minutes in position 1 on the selector switch. To avoid heat dispersion and damage to the plate, use flat bottomed pans with diameters the same as the plate (not more or less (fig. 14). Dry the bottom of the pan before putting it on the plate. Turn the knob only once the pan is on the plate. After use, for good conservation, the plate should be lightly greased with an oily cloth so that the surface is always clean and shiny; this avoids the formation of rust.

Never leave the plate alight without a pan or with an empty pan.

Turning the hot plate on – centre the pan on the plate and turn the corresponding knob to the desired position (see Table 2), the increasing numbers indicate increased power.

3.2. OVEN PERFORMANCE

Gas oven

The oven burner must always be ignited with the oven door open.

All D'amani cookers are fitted with valve thermostats which, besides regulating the temperature inside the oven, stop the gas flow should the burner accidentally go out, thus avoiding leakage of unburned gas.

For good cooking, we recommend preheating the oven for 10+15 minutes before putting the food in. The oven door should be opened as little as possible, avoiding the internal oven temperature changing rapidly, and therefore compromising the cooking results.

Ignition – open the oven door, press and rotate the oven knob (symbol ) in an anti-clockwise direction to the maximum position. The burner alights, depending on the model, manually, electronically, automatic electronic ignition incorporated in the knob.

- *Manually*: introduce a flame into the slit in the oven (fig. 15); the oven can always be lit with this method, even when there is a failure in the power supply.
- *Electronically*: simultaneously press the knob and the  button, fitted on the front control panel (fig. 12).
- *Incorporated in the knob*: it is sufficient just to press the knob.



When the burner lights, keep the knob well pressed for 5+10 seconds and then release. The burner remains alight due to heating the thermocouple that keeps the gas flowing through the safety valve. After carrying out these operations, close the oven door and turn the knob to the desired temperature.

The automatic ignition device (electronic ignition incorporated in the knob) must not be activated for more than 15 seconds, if the burner does not light after this time, release the knob and wait for at least one minute before making a new attempt at ignition. In some models, a special safety device discharges electricity for igniting the burner only when the door is open.

Electric ovens

STATIC OVENS: heat for the oven is produced by the electric elements fitted in the top (sky) and bottom (base) of the oven; the elements can work together or independently. This gives more even cooking, for example towards the end of cooking time food could need more heat at the top or the bottom. The temperature is kept constant by the thermostat according to the selected level, which varies between 50 and 250°C. Only open the door when it is strictly necessary during cooking. During this type of cooking, humidity loss from the food is slow and uniform.

FAN OVENS; heat is produced by the forced circulation of hot air inside the oven. A circular element next to the oven-motorised fan heats the air, and it circulates thanks to the fan which distributes the hot air evenly and rapidly. In fact, with this type of oven, cooking is faster than with traditional ovens and so you should set your cooking temperatures 10-20°C lower than normal. Once again the thermostat maintains the pre-selected temperature constant inside the oven, which can vary between 50 and 250°C. Oven preheating is only provided for cooking pastries, in other cases it is not necessary. It is ideal for defrosting and for cooking several dishes together without altering the flavours in any way.

To switch the oven on: turn the oven knob marked by the  or the  symbol, towards the right to the desired temperature, depending on the type of cooking.

Mixed ovens (gas/electric).

Certain models of cooker can have both gas and electric ovens. To ignite refer to the previous paragraphs for "gas ovens" and "electric ovens".

For safety reasons, they must be used separately.





3.3. USING THE GRILL

For safety reasons, the electric grill and gas oven cannot be used together.

The food should be placed on the oven grill and this must then be placed inside the oven depending on the type of food, e.g. flat or thin meat should be placed on the level closest to the grill, while a roll of roasting meat, poultry, etc. should be placed on the centre level, the juice tray should be fitted on the guides below the grill.

ALWAYS ENSURE THE DOOR IS CLOSED FOR GRILLING.

Using the electric grill:

- a) **MODELS WITH GAS OVEN:** to avoid simultaneous use of the oven and the grill, for safety reasons, the oven knob must be in the off position, i.e. the ● symbol, then press the electric grill button  which is on the front control panel (fig. 12).
- b) **MODELS WITH ELECTRIC OVEN:** are switched on by turning the oven knob  to the right (clockwise direction) until the indicator points to the grill symbol  (last position of the knob).
- c) **MODELS WITH MULTIPLE FUNCTION OVENS:** the function knob must be turned to the right (clockwise direction) to the grill position , then turn the oven thermostat knob and select the desired temperature. In position 6, using the grill with the fan and cooking on the rotisserie, the oven door must be closed and the thermostat on 160°C.
- d) **MODELS WITH MULTIPLE FUNCTION OVEN AND RADIATING GRILL**
The grill radiates heat for cooking, and the heat is produced by a special element that reaches a temperature of approx. 800°C in a few seconds, thus producing infrared rays which grant very rapid cooking through a transparent pyroceram plate. The layout of the heating filament and the elevated level of insulation mean that the heat is only concentrated on the surface of the pyroceram plate, thus giving uniform cooking and energy savings.
It should be cleaned once the oven has cooled down. The pyroceram plate allows better and easier cleaning, and it protects the heating element from splashes and fat.
The food should be placed on the oven shelf which is then placed inside the oven, depending on the type of food involved, for example, flat or thin meat such as steaks, T-bone steaks, chops, etc. should be placed on the runners nearest to the grill, while rolled roasts, poultry, etc., should be placed on the second runner from above. The drip tray should be placed directly underneath.
Working the grill: turn the function knob to the right (in a clockwise direction) to the required grill cooking position, then use the thermostat knob to set the temperature at 200°C. The oven door remains closed (the knob protection plate is not provided).
ATTENTION: if the pyroceram plate brakes, turn off the power supply and call your Authorised D'amani Service Centre.

WARNING: the accessible parts can become very hot when the grill is in use. Keep children at a safe distance.

3.4 ROTISSERIE

The rotisserie is used for roasting on the spit using the oven and the grill. After placing the drip tray on the lowest shelf, the following procedures must be followed: fit one of the forks to the spit, slide the food onto the spit fixing both ends with the two moving forks (to avoid the rotisserie motor overworking, try to distribute the food on the spit as evenly as possible) – place the spit rod into the support and then into the motor shaft – and start the motor with the  switch on the front control panel (fig. 12) and turn on the grill.

3.5 MINUTE TIMER

This mechanical minute timer goes from 0 to 60 minutes, with the sound of a bell when the selected time is over. To start the timer, turn the knob to the right to the required time; the knob automatically returns to zero and, at the end of the selected time, the bell rings indicating the cooking time has finished and the oven and/or grill should be turned off.

3.6 MULTIPLE FUNCTION COOKERS

The multiple function cookers are distinguished by the fact that the heat, inside the oven, can be spread naturally (convection) or forced (with the fan).

Thanks to this, by turning the selector to the desired function, 8 different types of cooking with separate temperature (thermostat knob) regulation are possible between 50 and 250°C; therefore even the most varied cooking requirements are satisfied. Depending on the models, these cookers have an end of cooking timer or a digital electronic programmer.

Cookers with timer (fig. 18):

Cookers with this device allow uninterrupted manual working and programming the cooking time of the oven between 0 and 120 minutes.

Uninterrupted manual working: set the type of cooking and the oven temperature using the “A” and “B” knobs respectively, turn the timer knob “C” in an anti-clockwise direction until it coincides with the !!!! symbol.

Programmed working: set the type of cooking and the oven temperature using the "A" and "B" knobs respectively, then turn the timer knob "C" in a clockwise direction to the desired cooking time. When the programmed time is over the oven turns off automatically.

Cookers with digital electronic programmer:

Cooking programmer and clock with a fluorescent display showing the settings for the time and the timer for up to 24 hours, the cooking can be programmed for up to 10 hours.

The cooking programmer allows 4 different types of working: **manual working, semi-automatic working with cooking time set, semi-automatic working with end of cooking time set, automatic working with cooking time and end of cooking time set.**

The set cooking time can be checked and changed at any moment by selecting the relative function.

The buzzer sounds for a max. of 7 minutes at the end of a timer cycle or at the end of a cooking programme, and it can be deactivated by pressing any of the function keys. The buzzer can have 3 different frequencies: to set them just press the "-" key before selecting a function.

When setting the cooking time, you must also take the time required for the oven to heat up into account (approx. 8-10 minutes to reach 200°C).

• Symbols on the control panel:

 = timer

 = cooking time

 = end of cooking time

-/+ = time settings



• Displayed messages:

 = cooking time and manual working

A = automatic working

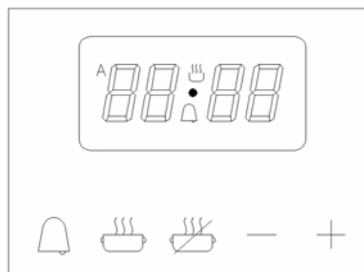

 = timer



Setting the time: Press the two   keys together and set the time using the +/- keys. This operation cancels any previously set programmes and manual working is activated.

Timer: to set the time, press the key with the bell symbol and set the required time using the +/- keys. When the time is up, the bell symbol appears and the buzzer sounds.

Manual working: If the cooker is programmed for manual working, the  symbol lights up on the display, set the type of cooking and ideal cooking temperature for the food (knobs F and T fig. 19) and the oven immediately starts up.



If an automatic programme has been set the "A" symbol lights up, in this case press the two   keys together to change from automatic to manual working.

With manual working, the timer can be set.



Semi-automatic working with cooking time set: Press the  key and set the cooking time using the +/- keys;

the "A" and  symbols light up. Set the type of cooking and ideal cooking temperature for the food (knobs F and T fig. 19) and the oven immediately starts up.

At the end of the set time, the oven turns off and the saucepan symbol goes out, the "A" symbol starts flashing and the buzzer sounds.

Semi-automatic working with end of cooking time set: Press the  key (the display shows the actual time) and set the desired end of cooking time using the +/- keys; the "A" and  symbols light up. Set the type of cooking and ideal cooking temperature for the food (knobs F and T fig. 19) and the oven immediately starts up.



When the end of cooking time coincides with the time shown on the display, the oven turns off and the saucepan symbol goes out, the "A" symbol starts flashing and the buzzer sounds.

Automatic working with cooking time and end of cooking time set: Press the  key and set the required cooking time using the +/- keys; the "A" and  symbols light up.

Press the  key (the display shows the actual time) and set the end of cooking time using the +/- keys; the saucepan symbol goes out and then lights up again when the time on the clock coincides with the initial time for cooking.

After choosing the type of cooking and ideal cooking temperature for the food (knobs F and T fig. 19) the oven starts automatically and remains on for the programmed period, at the end of the set time the oven turns off and the saucepan symbol goes out, the "A" symbol starts flashing and the buzzer sounds.

Example of automatic working: supposing that when you program the oven the display shows 9.00 o' clock, that the food requires 30 minutes at 180° with fan-assisted cooking and that you want the oven to turn off at 12.30:

a) press the  key and set cooking time at 0.30 using +/- keys; b) press the  key and set the end cooking time at 12.30 using +/- keys; c) turn the thermostat knob "T" to set the temperature at 180° and turn the selector switch "F" at  d) the oven will start automatically at 12.00 and it will turn off 30 minutes later, that is at 12.30; e) the buzzer will sound: in order to stop it, press any key.

LIST OF FUNCTIONS

D'AMANI's multifunction oven gives you flexibility at your fingertips. D'AMANI's engineers have perfected the even distribution of hot air throughout their ovens from top to bottom and side to side with strategically placed vents at the back of the oven. This performance is the same whether you have the smaller 72 litre oven or their giant 106 litre oven and allows you to batch cook or cook different dishes at once.



1 Conventional Oven for baking pastries, cakes & biscuits and roasts.



2 Cooking from below – on the bottom for pizzas and in the middle for slow cooking casseroles etc.



3 Cooking from above – ideal for cooking the top of the dish without grilling – cauliflower cheese, shepherds pie etc.



4 Grilling or cooking meat or poultry on the rotisserie with the door closed to save energy.



5 Grilling assisted with fan, this allows you to grill all cuts of meat, bacon and sausages or meat on the rotisserie with the food remaining succulent. For safe cooking the door must be shut.



6 Grilling assisted with fan,



7 Fan assisted cooking – heat is evenly distributed in the oven which heats up quickly, ideal for cooking roasts etc. as the meat seals itself quickly in a pre-heated oven and so retains more of its moisture.



8 A true fan oven - with the element behind the fan and so heat is evenly distributed by forced ventilation which enables fast cooking and baking. This allows you to batch bake using all the shelves or cook different dishes at once such as fish and meat without transferring flavour. **NOTE:-** A special stainless steel mesh filter covers the fan stopping fat from burning on the heating element. This prevents the smoke and fumes associated with the burnt fat. The filter is dishwasher proof.



9 Defrosting with the oven thermostat in the "0" position. Food can be defrosted using the fan without any heat.

Superfast defrost with the oven thermostat in the "50°C position" food can be defrosted quickly by using the Fan.



10 Oven light to keep an eye on your cooking without having to open the door.

3.7 COOKING HOB WITH GLASS-PLATE (Applicable models only)

The GLASS PLATE is an innovative cooking method: it combines the heat produced by a high yield element with a pyroceram plate that allows the infrared rays to pass through, for rapid direct cooking on the plate, special cooking in a pan, or it can be used as a food warmer.

The pyroceram surface is divided in two areas, with single or combined working. The two radiating areas are marked by a serigraph rectangle and are powered by special elements controlled by a touch-control Electronic Module.

Features of the GLASS-PLATE

Cooking speed and heat distribution – two separate heating elements with a filament that reaches approx. 800°C in a few seconds, generating infrared rays. The elevated level of glass fibre insulation avoids heat dispersion, with

obvious energy savings, and the special layout of the filament gives rapid and even heat distribution over all the glass plate.

Pyroceram surface – this is a non-toxic material that is rapid and easy to clean, it can reach a temperature of 500°C, and can be used for combined cooking using infrared rays (like the grill) or by direct contact on the plate.

Electronic module – the touch controls give easy and precise regulation.

Cooking – ideal for grilling directly on the plate, for sausages, hamburgers, meat, fish, vegetables, crepes, pizzas, etc.; this method gives excellent quality and healthy cooking, as the flavour of the food is unchanged because the glass does not absorb flavours, there are no carbon deposits, no fat is used. It is also ideal for cooking in pans for slow, gentle cooking (at low and uniform temperatures) or it can be used as a food warmer.

Performance of the GLASS-PLATE

Two 800 W elements.

The pyroceram plate reaches a maximum temperature of 500°C.

Time required to reach 300°C = 4, 5 minutes.

Energy consumption to reach 300°C = 100 watts.



Cleaning and recommendations

The glass plate should only be cleaned when it has cooled down. Use the supplied liquid detergent to wash the glass, or alternatively soapy water. For more stubborn dirt, use the scraper supplied with the cooker. **Do not use abrasive pads, such as Scotch Brite, wire wool or similar.**

For cooking in pans, we recommend using only smooth flat-bottomed pans, take care when using iron pans or pans with rough bottoms as they can scratch and mark the glass surface, pans with aluminium or copper bottoms can leave marks. Please only use pans that are suitable for use with ceramic cooktops. If unsure please check with the manufacturer of your pans.

When cooking is finished, the heated area remains hot for a certain period of time, take care not to place your hands on top of it. Keep children at a safe distance.

Working:

- Touch the  symbol to turn the Electronic Module on and off.
- If the Module is on but no +/- sensors are activated, it automatically turns off after 10 seconds.
- If the heat selector is turned to "0", it automatically turns off after 10 seconds.
- Touch the +/- sensors to select a heat level between 1 and 9.
- If a heat level is selected for just one area, the other area automatically turns off after 10 seconds if no level is selected for it.
- If just one heating area is activated, the other can be activated at any moment by touching the +/- sensors.
- When a heating area is activated, pressing the +/- keys together can deactivate it.
- For added safety, if a sensor is touched for more than 10 seconds all the heating areas are automatically turned off.
- If a heating area is turned off but the display shows "H", it means that there is residual heat in the area and therefore attention must be paid to avoid burns. The "H" symbols goes out automatically when the residual heat has reduced sufficiently.
- Automatic heat push: At the beginning of the cooking cycle, the heating areas can be set to the maximum level for a period of time calculated automatically by the Module, thus allowing the elements to reach the set cooking temperature as quickly as possible. The automatic heat push is activated by touching the "+" sensor immediately after turning the Module on, and then selecting the required output, a dot (•) appears alongside the set value. When the heat push time is over, the dot disappears and the heating areas continue to work at the set level at even temperatures.
- To avoid activating the automatic heat push, touch the "-" key after turning the Module on, the selector goes automatically to 4, then set the desired level. The selected functions can be arrested by touching the  key for a few seconds, a buzzer lights up and sounds each time you attempt to change the set levels. At this point, the Electronic Module can be turned off, and the function arrest remains activated. To deactivate the function arrest, touch the  key again for a few seconds.

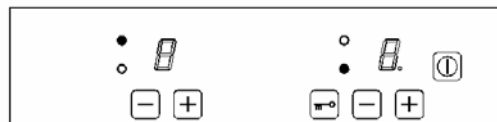

ATTENTION: if the pyroceram plate should break, turn off the power supply immediately and call your authorised D'amani Service Centre.

3.8. FITTING THE FAT FILTER ON THE FAN COVER INSIDE THE MULTIPLE FUNCTION GIANT OVEN (fig. 20).

- Place the tabs A-B in line with the holes in the fan cover A1-B1.
- Press the rod C so that the tabs fit perfectly into the holes A1-B1.

3.9. FITTING THE GAS BURNERS TO THE HOB

Burners: auxiliary, semi-rapid, rapid, super rapid: for correct fitting of the burners, flame diffusers and the enamel burner caps in the cups in the hob, follow the sequence given in fig. 21. Take care that the burner guides on the cup and flame diffuser of the burner perfectly correspond.

Treble crown burner: fit the flame diffuser to the burner support so that it cannot rotate (fig. 22).

Fish kettle: fit the flame diffuser to coincide with the hole in the bottom part, with the electronic ignition candle fitted in the cup on the hob (fig. 23).

3.10 TELESCOPIC RUNNERS (only for certain models)

The telescopic runners guarantee greater stability to the oven accessories. Placing the food on the shelves or on the tray is easier and safer.

The shelves and trays must be securely fitted into their housing on the runners.

We recommend using oven gloves during cooking or while the oven is still hot.

3.11 Standard Wire Racks

Insert pictures of how the shelves should be installed into the oven so that all the safety features of the shelf operate correctly.

3.12 ABNORMAL OPERATION

Any of the following are considered to be abnormal operation and may require servicing:

Yellow tipping of the hob burner flame.

Sooting up of cooking utensils.

Burners not igniting properly.

Burners failing to remain alight.

Burners extinguished by opening or closing oven door.

Gas valves, which are difficult to turn.

In case the appliance fails to operate correctly, contact the authorised service provider – CUCINA Appliances Tel:1800 444 357.

4. CLEANING

Before cleaning turn off at the mains and leave the oven and burners to cool.

To clean the stainless steel, enamelled, glass parts and the front control panel, we recommend using a sponge or damp cloth with a non abrasive cleaner, avoid using steel wool, abrasive powders and corrosive substances that could scratch.

To keep the internal enamelled parts shiny for a long time, they should be cleaned after every use with warm soapy water. The grid guides and drip pan can be removed by unscrewing the nuts/washers G (fig. 24) for easier cleaning; to reassemble, place the 2 P extensions of the side guides in the holes F on the bottom of the oven, line up the 2 front eyelets of the guides with the screws fitted to the sides, fix the guides with the nuts/washers G. Do not wash the oven when it is still hot and do not use abrasive substances or products.

Do not allow acid or alkaline substances to remain in contact with the enamelled surfaces for any length of time, such as: VINEGAR, COFFEE, MILK, SALT WATER, LEMON JUICE, TOMATO JUICE, ETC.

To clean the inside of the oven door (according to the model): a) open the oven door and unscrew the two screws that fix the internal glass; then remove the glass, paying attention to the sealing gasket. b) for models with triple glazed oven door, remove the superior frame using a screw driver, as given in fig.10A, and let slide the glass out of the guides.

We recommend great caution and precision in doing these operations.

The burners, covers, flame diffusers should be periodically washed, we recommend using soapy water, before replacing them in their housing they should be dried carefully, and check that the holes in the flame diffusers are clear.

**INDICATIVE TIMES AND TEMPERATURES FOR
COOKING WITH A VENTILATED OR STATIC OVEN**

Oven Cooking	Amount KG	Oven Temperature in °C	Shelf position from the bottom	Cooking time with ventilated oven	Cooking time with static oven
Pastries:					
Sponge cake		170	3	35'	50'
Apple tart		180	3	35'	50'
Fruit tart		180	3	30'	45'
Flat bread		170	3	35'	50'
Bread loaves and plaits		170	3	40'	55'
		180	3	25'	35'
Biscuits		110	2-3	120'	150'
Meringue		175	3	20'	35'
Bigné		175	2	35'	45'
Soufflé					
Meat:					
Roast pork	1	190	3	90'	100'
Pork chops	1	180	2	60'	75'
Leg of pork	1,5	180	2	90'	105'
Sausages	1,5	170	2	45'	60'
Fillet of beef	1	170	2	75'	90'
Roast beef	1	180	3	45'	65'
Roast veal	1	180	3	90'	105'
Veal roll	2	180	2	100'	110'
Leg of lamb	1	200	3	95'	115'
Shoulder of lamb	1	175	2	70'	85'
Roast pheasant	1	200	2	70'	95'
Roast hare	2	175	2	75'	90'
Roast rabbit	2	175	2	100'	110'
Turkey roll	1,5	180	3	70'	85'
Guinea fowl	1	180	3	65'	85'
Duck	2	180	2	90'	110'
Chicken	1	175	3	75'	90'
Fish:					
Mackerel	1	160	3	50'	60'
Bream	1,5	180	2	45'	60'
Sole gratin	1	200	2	25'	35'
First courses:					
Lasagne		200	3	40'	55'
Cannelloni		200	3	40'	55'
Baked tagliatelle		180	3	70'	80'
Various:					
Neapolitan pizza		200	3	20'	30'
Baked apples		180	2	60'	70'

The reported data refer to laboratory tests: several factors can influence times and quality of cooking, e.g. the place where appliances are installed, room temperature, gas pressure, voltage, etc. Therefore, the above data is only indicative.

BURNER SPECIFICATIONS

Type of gas:

U-LPG

- Nominal pressure
2.75kPa

Natural

- Nominal pressure
1.0kPa

Type of burner	By pass Ø 1/100 mm	U-LPG		Natural gas	
		Injectors Ø 1/100 mm	Nominal thermal capacity	Injectors Ø 1/100 mm	Nominal thermal capacity
			MJ/h max.		max MJ/h
Cooking hob burners					
Auxiliary (small)	27	50	3.2	90	4.0
Semi-rapid (medium)	29	70	6.4	120	7.1
Rapid (large)	39	90	10.5	155	11.8
Treble crown (Wok)	65	100	13.0	175	15.0
Fish kettle	60	100	13.0	165	13.0
Gas oven burner					
60l : (60x50-60x60-70x50-70x60)	55	94	11.5	155	11.5
Giant oven	60	120	18.0	200	18.0

Glass plate and electric plate features

TABLE 2





GIANT OVEN COOKER WITH GLASS PLATE : 800 – 800 W

Corresponding positions of the knob and absorbed power

Plate diameter in mm	consumption knob position and W consumption				
	0	1	2	3	4
80	0	90	180	200	450
110	0	140	300	400	700
145	0	187	250	750	1000
180	0	300	600	900	1500

Absorbed power by the electric oven with thermostat

Table 3

MODEL	BASE RESISTANC E 	SKY RESISTANC E 	GRILL RESISTANC E 	MAXI-GRILL RESISTANC E 	CIRCUIT RESISTANC E 
Gas – Electric model : 60x50-60x60-70x50-70x60	1400 W	600 W	1500 W		
MIXED OVEN MODEL 70X60	1650 W	900 W	1500 W		
MULTIPLE FUNCTION MODELS:		600 W	1500 W		2000 W

MULTIPLE FUNCTION MODEL:60X50-60X60-70X50-70X60	1400 W	600 W	1500 W	2100W	2000 W
RADIATING GRILL MODEL: 60X60-70X60	1900 W	700 W	1800 W	2500W	2000 W
MULTIPLE FUNCTION GIANT OVEN	1750 W	1000 W	2000 W	3000W	2500 W
DOUBLE OVEN:	LT OVEN 60 LTS	1400 W	600W	1500 W	2100 W
	RT OVEN 30 LTS	1200 W	500 W	1000 W	

Electric oven consumption

MODELS	Usable oven volume	Consumption to reach 200°C kWh	Consumption to maintain 200°C kWh for one hour	Total kWh	Electric oven	
Models: 60x50-60x60-70x50-70x60	60	0,5	0,8	1,3	D'AMANI SpA	
Multiple function model: 60x50-60x60-70x50-70x60	60	0,3	0,8	1,1	Modello	
Radiating grill model: 60x60-70x60	60	0,7	0,49	1,19	Usable oven volume	l
Multiple function Giant Oven model	92	0,88	1,27	2,15	consumption: to reach 200°C to maintain 200°C for one hour	kW
					TOTAL	kW
					Cleaning cycle consumption	kW
					CENELEC Standards	DH 376

The information given in the above table refers to laboratory tests. Various factors can influence consumption and time, e.g. room temperature, gas pressure, etc. therefore the above data is only indicative.

Wiring diagrams

PL	oven light button	LS	signal light	M3	incorporated electric ignition microswitch
PG	rotisserie button	LA	oven light	RV	ventilator resistance
PAE	electric ignition button	G	rotisserie	TEP	timer
PRG	grill resistance button	RG	grill resistance	V	ventilator
TE	electric thermostat	RFC	oven sky resistance	PC	cooking programmer
CTE	electric thermostat selector switch	RFS	oven base resistance	PE	electric plate
CPE	small electric plate selector switch	M1	oven safety microswitch	AE	electric ignition
P	large electric plate selector switch	M2	grill cut out microswitch	S	klaxon
CPE					
G					

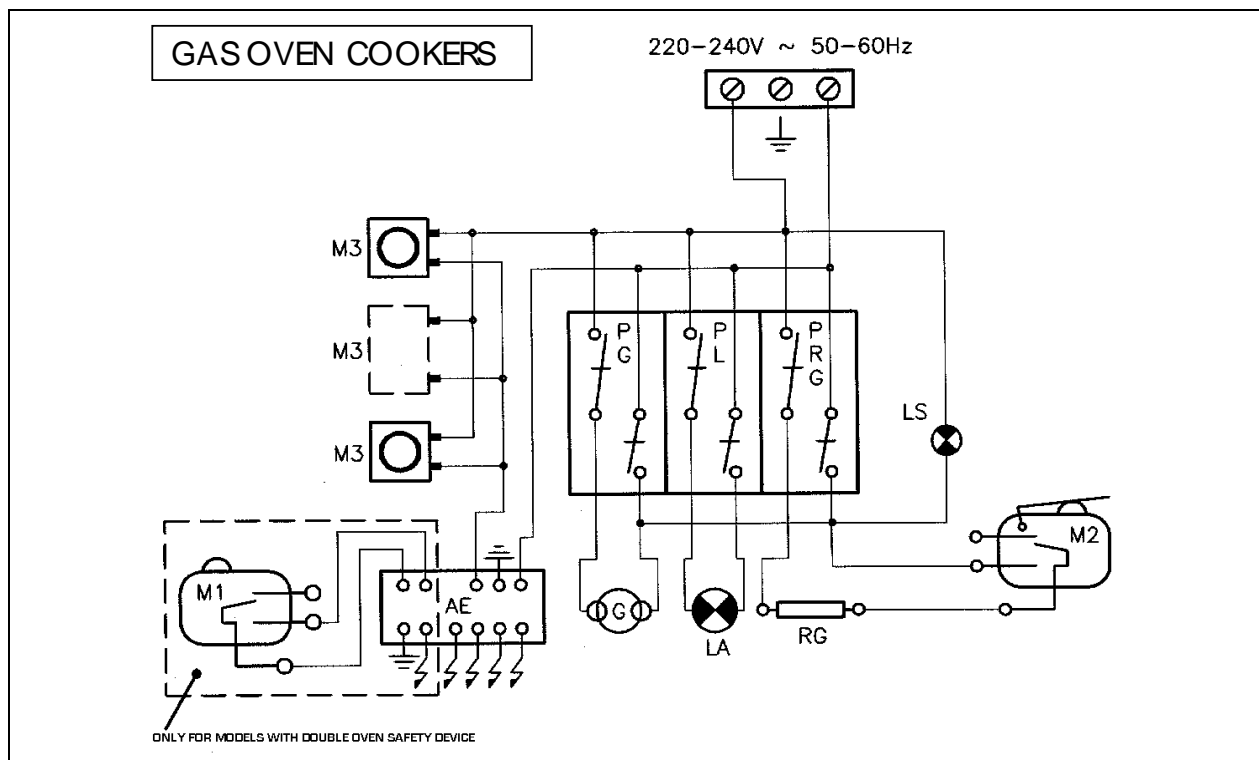

ELECTRIC OVEN COOKERS 60L

220-240V ~ 50-60Hz

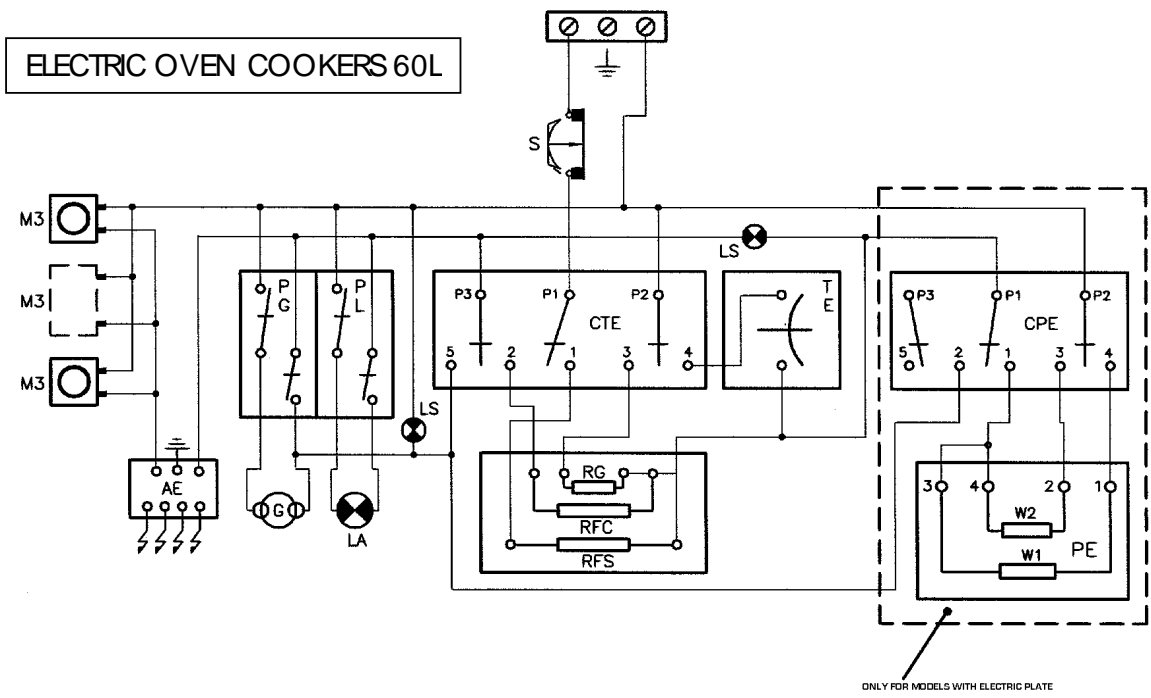

MULTIPLE FUNCTION OVEN

220-240V ~ 50-60Hz

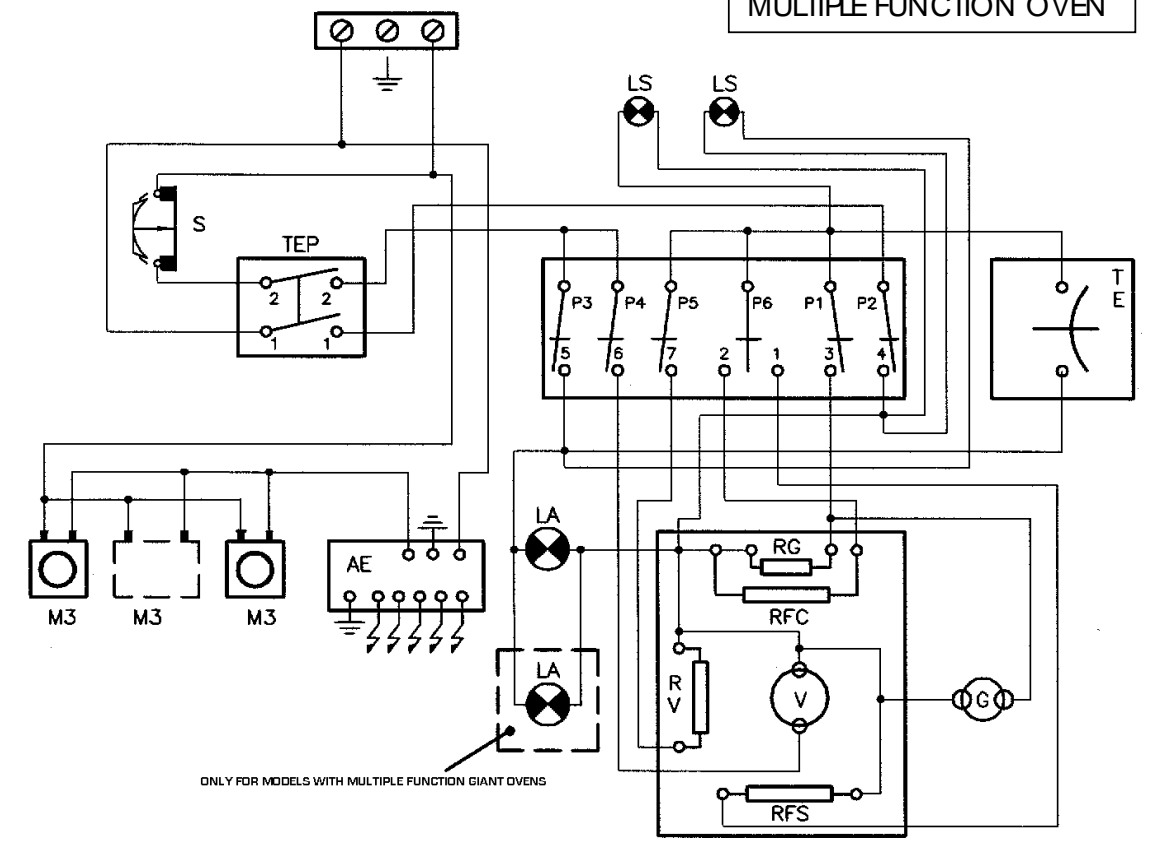

220-240V ~ 50-60Hz

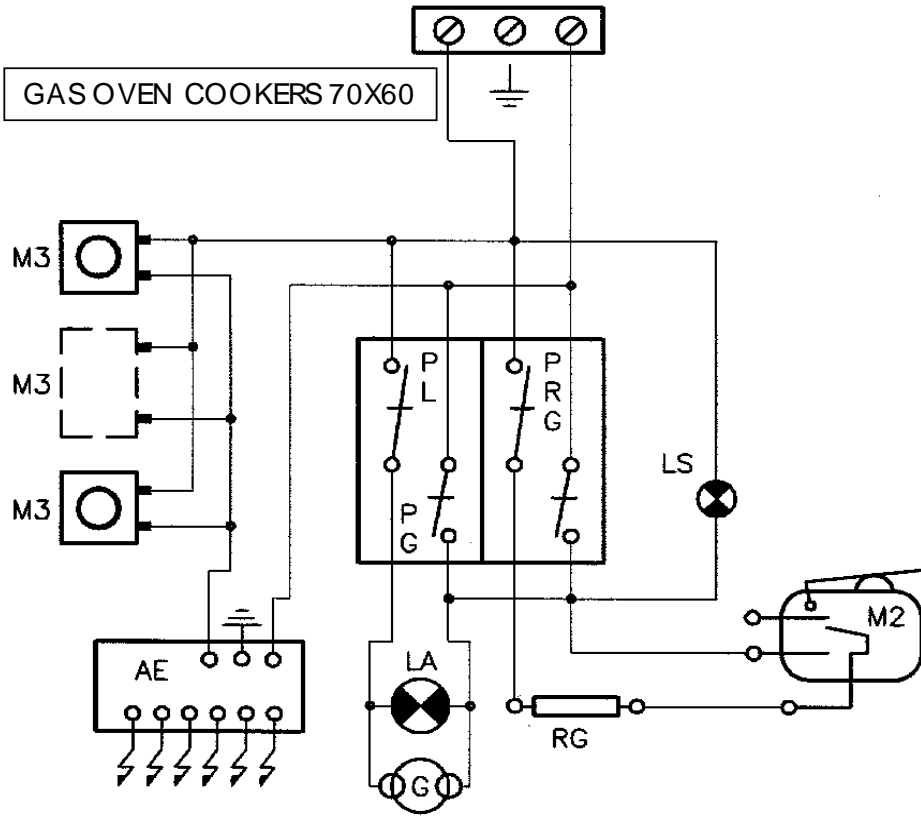

220-240V ~ 50-60Hz

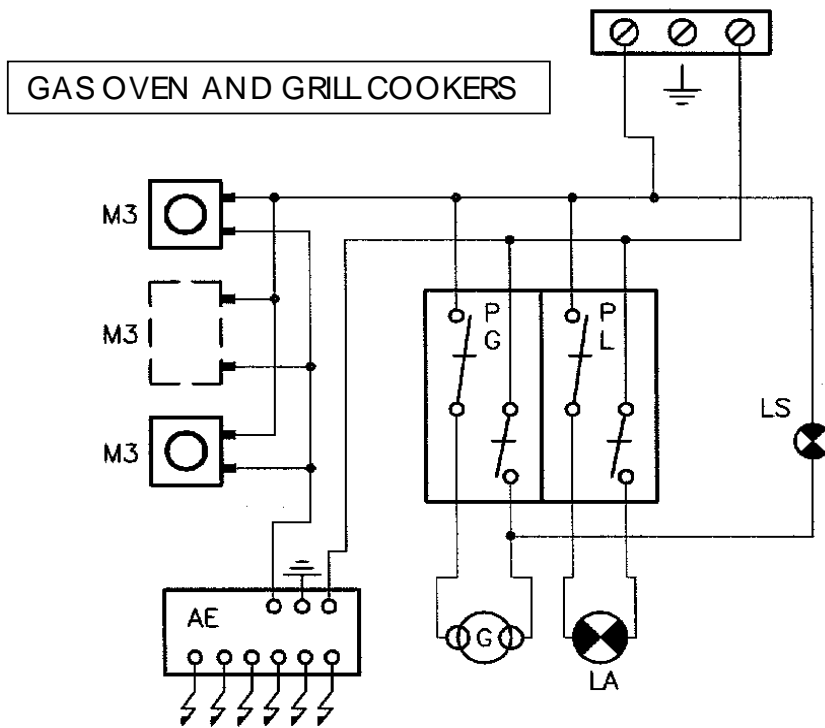

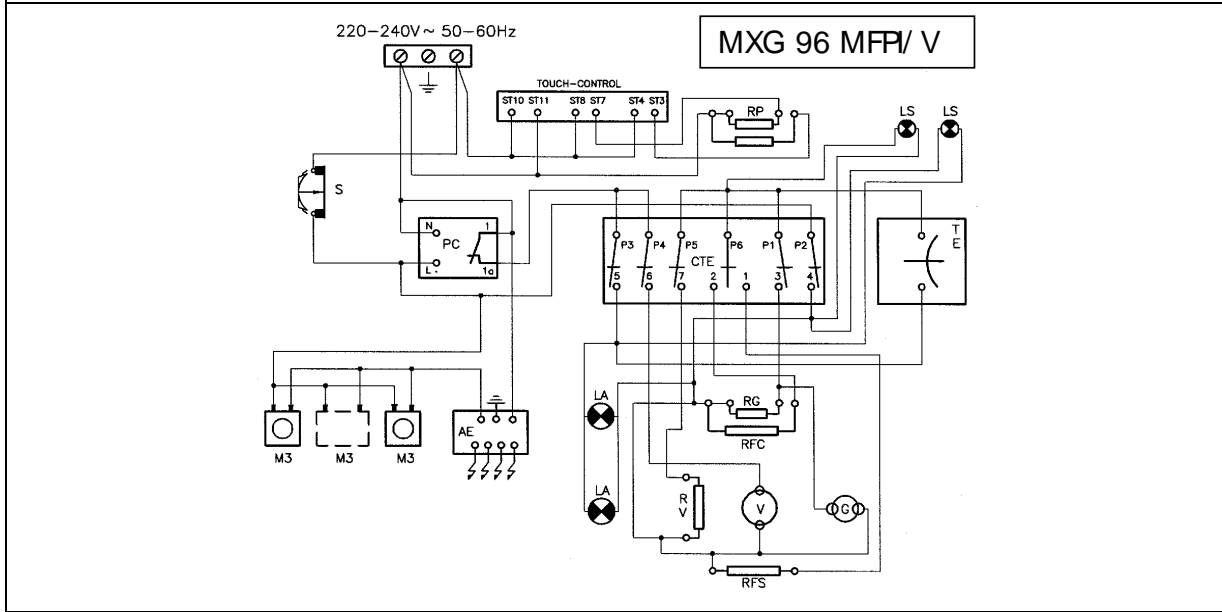
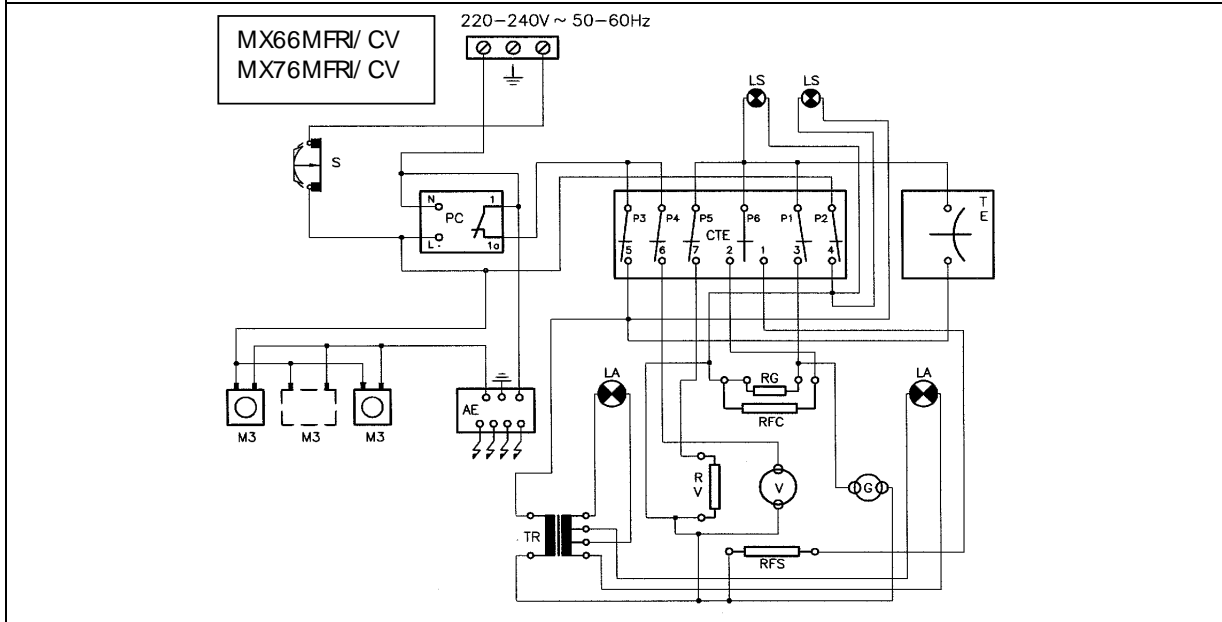
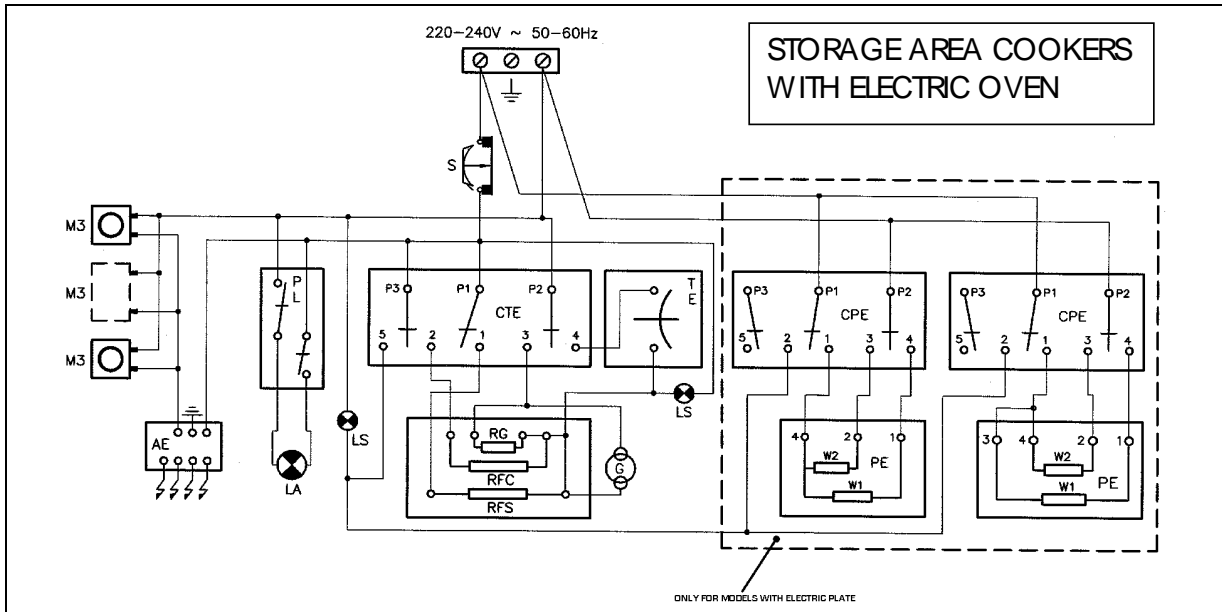

LOFRA®

Sede Via Euganea Treponti, 16 – 35037 TEOLO (PADOVA) – ITALY

Tel.: **39-49-9997111

Telefax: **39-49-9902042

www.D'amani.it

D'AMANI S.p.A. reserves the right to make changes to the product in any given moment without prior notice, for technical and production reasons.