

**morphy richards®**

smart ideas for your home

Bread Maker

# INSTRUCTION MANUAL

Model: MRBRD3

Read these instructions carefully before  
using this appliance for the first time.

**STORE THESE INSTRUCTIONS CAREFULLY**

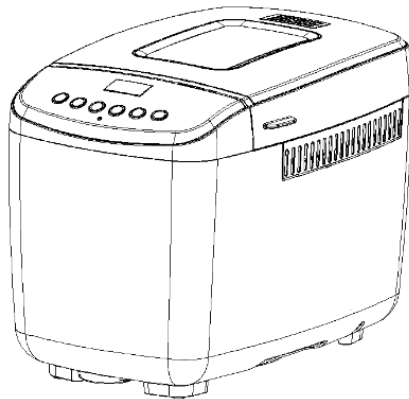

For product hints and tips plus more join us at

[www.morphyrichards.com.au](http://www.morphyrichards.com.au)



facebook.com/MorphyRichardsAUS



instagram.com/morphyrichardsau

## IMPORTANT SAFETY INSTRUCTIONS

**WARNING:** To reduce the risk of fire, electric shock, injury to persons or damage to property, follow basic precautions including the following:

- If the supply cord is damaged, it must be replaced by the manufacturer or its service agent or a similarly qualified person in order to avoid a hazard.
- Keep the appliance and its cord out of reach of children.
- This appliance is not intended for use by persons with reduced physical, sensory or mental capabilities or lack of experience and knowledge unless they have been given supervision or instruction concerning use of the appliance by a person responsible for their safety.
- Children should be supervised to ensure that they do not play with this appliance.
- In the absence of supervision, the cleaning and maintenance work should not be done by a child.
- Do not exceed the maximum quantities of flour and raising agent stated in recipes (supplied).
- **WARNING:** Misuse of appliance could cause personal injury.
- **WARNING:** This product has a heating element which is subject to residual heat after use.
- This appliance is not intended to be operated by means of an external timer or a separate remote-control system.
- Use of accessories not recommended or sold by the original manufacturer may cause risks of fire, electric shock or personal injury.
- This appliance must be used in accordance with the instructions and must not be used for other purposes.

- This appliance is intended to be used in household and similar applications such as:
  - staff kitchen areas in shops, offices and other working environments;
  - farm houses;
  - by clients in hotels, motels and other residential type environments;
  - bed and breakfast type environments.

## Location

- Always locate your appliance away from the edge of a worktop.
- Ensure that the appliance is used on a firm, flat surface.
- For indoor use only. Do not use the appliance outdoors, or near water.
- Do not place the appliance on or near heat sources such as gas or electric stove, ovens, or burners.

## Mains cable

- The mains cable should reach from the socket to the base unit without straining the connections.
- Do not let the mains cable hang over the edge of a worktop where a child could reach it.
- Do not let the cable run across an open space e.g. between a low socket and table.
- Do not let the cable run across a cooker or toaster or other hot area which might damage the cable.

## Treating scalds

- Run cold water over the affected area immediately. Do not stop to remove clothing, seek medical help quickly.

## Other safety considerations

- **WARNING:** To protect against fire, electric shock and personal injury, do not immerse cord, plugs, or appliance in water or other liquid.
- **WARNING:** Extreme caution must be used when moving the appliance when containing hot food, water, or other hot liquids.
- Unplug from the socket when not in use, before putting on or taking off attachments, and before cleaning
- Do not operate any appliance with a damaged lead or plug, or after an appliance has malfunctioned, or has been dropped or damaged in any way.
- To avoid damaging the appliance, do not place the Baking Pan or any object on top of the unit.
- Do not clean with scouring pads. Do not wash the Baking Pan, Kneading Blade, Measuring Cup or Spoons in a dishwasher.
- Keep the appliance and the cable away from heat, direct sunlight, moisture and sharp edges.
- The Baking Pan must be in place prior to switching on the appliance.
- Always remove the plug from the socket whenever the machine is not in use, when attaching accessory parts, cleaning the machine or whenever a disturbance occurs. Pull on the plug, not the cable.

## Electrical requirements

- Check that the voltage on the rating plate of your appliance corresponds with your house electricity supply which must be A.C.
- **WARNING:** This appliance must be earthed.

## Proper use

- Only use your bread maker for baking bread in a household environment. Do not use the appliance for drying foodstuffs or other objects.
- Do not use the bread machine outdoors. Use accessories recommended by the manufacturer only. Accessories not recommended may cause damage to the appliance.

**READ CAREFULLY AND KEEP FOR FUTURE REFERENCE**

## INTRODUCTION

Thank you for purchasing a Morphy Richards Bread Maker. As you will soon find out there is nothing like the aroma of fresh homemade bread throughout your home.

Please take some time to familiarise yourself with your new Bread Maker. This manual explains what you need to do before first use as well as explaining some hints and tips to create perfect breads and cakes every time.

## SPECIFICATIONS

Model:	MRBRD3
Colour:	White/Black
Rated Voltage:	220-240V~50Hz
Rated Heating Power:	850W
Rated Motor Power	100W
No. of Programs:	16
Loaf sizes	3
Crust options	4
External Dimensions (L x W x H):	428 x 267 x 296mm
Net Weight:	6.31kg

You can use this bread maker to bake according to your taste.

- Choose from 16 different baking programs.
- Use ready-to-use baking mixtures, or bake from scratch.
- Knead different dough types or make jam.
- The Gluten Free program caters to gluten-free baking mixtures and recipes with gluten-free flours, such as corn flour, buckwheat flour and potato flour.

## PRODUCT OVERVIEW

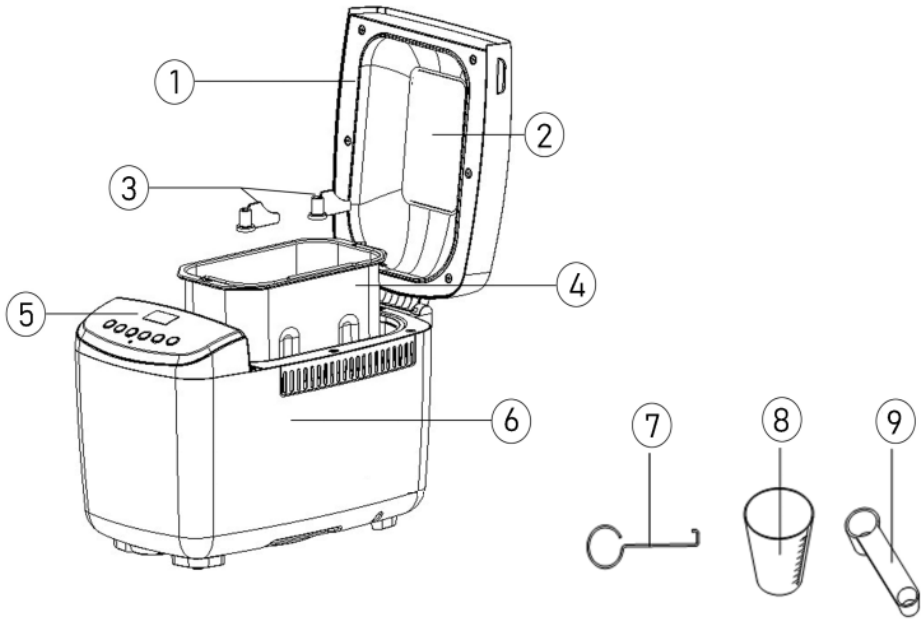

1. Bread maker lid
2. Viewing window
3. Kneading blades
4. Baking pan
5. Control panel
6. Main unit
7. Kneading blade remover
8. Measuring cup
9. Measuring spoon (x2)

## CONTROL PANEL

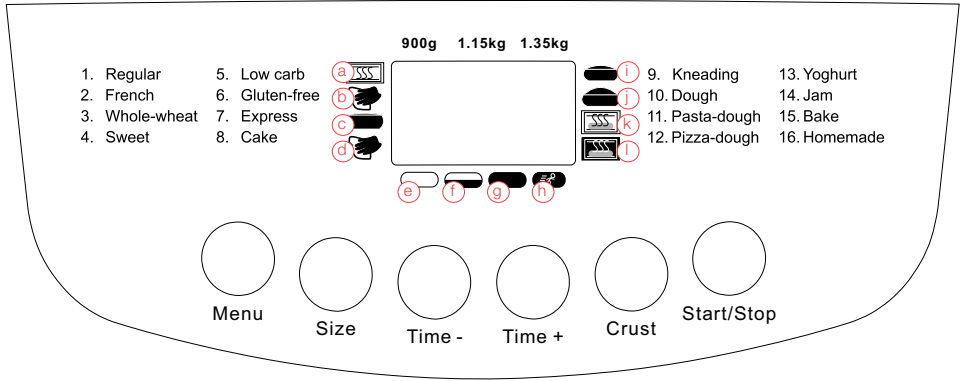

(a) Preheat

(b) Kneading 1

(c) Rise 1

(d) Kneading 2

(e) Light crust colour

(f) Medium crust colour

(g) Dark crust colour

(h) Rapid Bake

(i) Rise 2

(j) Rise 3

(k) Bake

(l) Keep Warm

**Menu** - Select the desired baking program. The program number and corresponding baking time will appear on the display.

**Size** - Select the gross loaf weight (900g, 1.15kg, 1.35kg) by pressing the button until the indicator on the display appears beneath the desired weight.  
**Note:** Loaf size cannot be adjusted for programs 9, 10, 11, 12, 13, 14 & 15.

**Time - & Time +** - Press to set time-delayed baking as desired. The total set time will appear on the display.

**Crust** - Select the degree of browning {Light (e) > Medium (f) > Dark (g) > Rapid (h)} by pressing the button until the indicator on the display appears above the desired crust icon.

**Start/Stop** - Press to Start/Stop a program or delete a set timer. To finish operation and delete the setting, hold for 3 seconds until a long beep is heard.  
**Note:** Do not press the Start/Stop button to check bread.

## BEFORE FIRST USE

Before first use, please take a few minutes to read this instruction book and find a place to keep it handy for future reference. Please pay particular attention to the safety instructions.

1. Wash the Baking Pan (4), Kneading Blades (3) in hot soapy water and dry thoroughly.
2. Wipe the outside surface of the Main Unit (6) with a clean, damp cloth.  
**DO NOT** use scouring pads or any abrasives on any part of the Bread Maker.
3. If using for the first time, use a little oil, butter or margarine to grease the Baking Pan (4) and bake empty for about 10 minutes on Bake program 15. **NOTE:** During manufacturing it is necessary to lightly grease some parts of the appliance. This may result in the unit emitting some vapour when first used, this is normal.
4. Allow to cool and then wash the Baking Pan (4) again in hot soapy water and dry thoroughly.
5. Place the Kneading Blades (3) on the Rotating Shaft in the Baking Pan (4).
6. Place ingredients into the Baking Pan. Please keep to the order as mentioned in the recipes.
7. Usually the liquid is placed in the Baking Pan (4) first, followed by dry ingredients (e.g. sugar, salt and flour etc) and yeast or baking soda should always be the last ingredient - refer to below diagram as a guide.

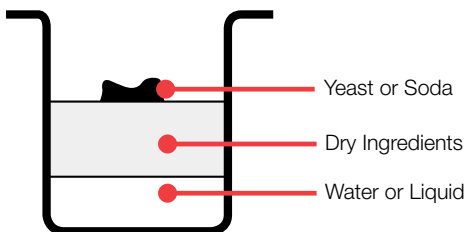

## USING YOUR BREAD MAKER

The bread maker has three settings to make either 900g, 1.15kg or 1.35kg loaves (approximate weight, dependent upon recipe).

A beep signals when extra ingredients, such as fruit and nuts, can be added so they don't get chopped by the Kneading Blades (7).

1. Pull the Baking Pan (4) upward out of the appliance and remove from the Main Unit (6).
2. Push the kneading blades (3) onto the drive shafts in the baking pan. Ensure they are firmly in place.
3. Carefully measure the ingredients and add to the baking pan, in the order listed in the recipe.

**IMPORTANT:** Use tepid water (21-28°C). When adding the yeast, ensure it does not come into contact with the water, or it will activate.

4. Put the Baking Pan (4) back into the Main Unit (6). Ensure it is positioned correctly.
5. Close the Lid (1).
6. Plug the Bread Maker into the mains outlet. The Bread Maker will automatically default to the Basic program 1.
7. Select the desired program by pressing the Menu Button. Every time you press the button you will hear a beep to confirm.
8. Choose the desired crust colour by pressing the Crust button. You can also select the 'Rapid' setting to shorten the baking time.

**NOTE:** For programs 9, 10, 11, 12, 13 or 14, the Crust setting is not available. The 'Rapid' setting is only available for programs 1, 2, 3 and 4.

9. Press the Size button to choose between 900g, 1.15kg, or 1.35kg loaves.
10. If you wish to delay the start time, set the time delay now. Use the 'Time -' & 'Time +' buttons to adjust the time. You can delay between 10 minutes and 15 hours. The displayed time includes baking time.

**NOTE:** This time delay function is not available for programs 9, 11, 13, 14 or 15.

### Starting a Program

1. Hold down the Start/Stop Button for a few seconds to start the machine, the Bread Maker will beep.
2. Occasionally, condensation may occur in the viewing window during baking. The appliance lid can only be opened during kneading. **DO NOT** open the appliance lid during baking. The bread can collapse.

### Removing kneading blades

3. This function allows you to remove the dough kneading blades before the baking phase. This is not mandatory, but has the advantage that the unaesthetic holes in the finished bread are slightly smaller because they are caused only by the thin shafts. The bread is no longer torn by the kneading blades if removed it from the baking pan.
4. During the 2nd rising phase, 10 beeps sound and “RMV” will flash on the display.
5. Press the Start/Stop button to pause the program sequence for 10 minutes. During this 10 minute pause, the remaining program time flashes on the display.
6. Remove the dough kneading blades, then press the Start/Stop button to continue the program. If the Start/Stop button hasnt been pressed in 10 minutes, the program will automatically continue after a 10 minute pause. Note: This function does not apply to programs 7, 8, 9, 11, 12, 13, 14 or 15.

### Ending a Program

7. The Bread Maker will beep when finished and the display will show 0:00. It will automatically switch to Keep Warm for 60 minutes. You can terminate the warming function by pressing the Start/Stop button until two acoustic signals are heard. NOTE: The “keep warm” phase does not apply to programs 9, 10, 11, 12, 13 or 14.

**WARNING: USE OVEN GLOVES.** Switch the Bread Maker off at the wall. Lift the Lid (1) and remove the Baking Pan (4). Allow to cool for a few minutes.

8. Remove the loaf from the Baking Pan (4) and allow to cool fully on a wire rack. Remove the Kneading Blades (3) from the base of the loaf using the Kneading Blade Remover (7).

Note: Do not use any metal objects to remove bread, as they will scratch the non-stick coating. After removing the bread, immediately rinse the baking pan with warm water. This prevents the kneading blades from sticking to the driving shaft.

Select the desired baking program by pressing the menu button. The corresponding program number is shown on the display and detailed below. The baking time depends on the selected program combinations.

### 1. Basic

This program is suitable for baking white or brown breads, which largely consist of wheat or rye flour. The bread will have a compact consistency.

### 2. French

This program is suitable for baking fluffy breads made from finely ground flours. The bread will be fluffy with a crispy crust.

### 3. Whole Wheat

This program is suitable for processing strong flours such as wholemeal wheat flour or wholemeal rye flour. The bread will have a heavy and compact consistency.

### 4. Sweet

This program is suitable if you would like to add additional sugar or ingredients such as fruit juice, dried fruit, coconut flakes, raisins or chocolate to your bread. The program provides a fluffy, airy bread.

### 5. Low carb

Use this program to bake low-carbohydrate breads.

### 6. Gluten Free

Gluten-free flours and baking mixes have different rise properties and need more time to absorb fluids. This program has extended rise and baking times, so it is suitable for breads made with gluten-free flour or gluten-free baking mixes.

### 7. Express

The times for kneading and baking as well as the rise time are greatly reduced in the Express program. This program is only suitable for recipes that do not require any strong flour types or other heavy ingredients. The bread will be less airy than breads made with other programs.

### 8. Cake

Use this program to bake cakes according to your own recipes or cake mixes.

### 9. Kneading

This program is for kneading dough only.

### 10. Dough

This program is for yeast dough for bread rolls, pizza or other pastries. A timer program is possible within this function. The program includes kneading and rising phases.

### 11. Pasta dough

Prepare pasta dough with this program. The program is 15 minutes long and only consists of a kneading phase. A timer program is not possible.

### 12. Pizza dough

This program takes 45 minutes and consists of two kneading and two rising phases. A timer program is possible.

### 13. Yoghurt

This program can make yoghurt from cow or soy milk.

### 14. Jam

This program is used to make jam, marmalade and other fruit-based spreads. See enclosed recipes for detailed instructions.

### 15. Bake

If bread baked on a different program, is too light or not baked through, use this program for additional baking. You can also bake ready-made dough with this program. The bread will be kept warm for nearly an hour after the end of the baking operation. This prevents the bread from becoming too moist.

### 16. Homemade

The Homemade program allows you to create up to 8 custom programs:

- Use the MENU button to scroll through the programs until you reach Number 16
  - There are 8 individual menus that can be customised under this program
- Press the CRUST key to select the first menu (1) to customise
- When number 1 is showing, then press the SIZE button to begin scrolling through the process settings:
  - A small flashing arrow will now appear on the display at the top left hand side against the first program step>
  - PREHEAT> use TIME -/+ to select preheat time
    - (NB: reduce the factory default setting to zero should you not wish to preheat the bread maker)
- Press the SIZE button to confirm the setting time and move to the next step
  - KNEAD 1> use TIME -/+ to select kneading time
- Press the SIZE button to confirm the setting time and move to the next step
  - RISE1> use TIME -/+ to select rise time
- Press the SIZE button to confirm the setting time and move to the next step
  - KNEAD 2> use TIME -/+ to select second kneading time
- Press the SIZE button to confirm the setting time and move to the next step
  - RISE 2> use TIME -/+ to select second rise time
- Press the SIZE button to confirm the setting time and move to the next step
  - RISE 3> use TIME -/+ to select third rise time
    - (NB: reduce the factory default setting to zero should you not wish to rest the dough a third time)
- Press the SIZE button to confirm the setting time and move to the next step
  - BAKE> use TIME -/+ to select preferred baking time
- Press the SIZE button to confirm the setting time and move to the next step
  - KEEP WARM> use TIME -/+ to select preferred keep warm (to a maximum of 60 mins)

## PROGRAM DESCRIPTIONS

- Press **START** to confirm settings
  - Pressing the **START** key to confirm will also **EXIT** the custom setting returning you to the first pre-programmed setting
  - Use the **MENU** button to scroll through the programs until you reach Number 16
  - Press the **CRUST** key to select the custom menu required
  - Press **START** to begin customised setting
- If at any time an error is made during the programming simply press **MENU** + **SIZE** buttons together to restore factory settings

**WARNING:** Never use larger quantities than those specified in the recipes. Too much dough can rise out of the baking pan and drop on to the heating elements, causing a fire.

## USING THE TIMER

The timer function enables delayed baking. Use the 'Time -' & 'Time +' buttons to set the desired end time.

1. Select a program. The display indicates the required baking time. Using the 'Time -' & 'Time +' buttons you can change the end time of baking in 10 minute increments.
2. Hold down the buttons to set the desired time faster. The display shows the total duration of baking time including the delayed time.
3. Confirm the timer setting by pressing the Start/Stop button.
4. The colon on the display will flash and the programmed time will begin.
5. When the baking process is complete, ten acoustic signals will sound and the display indicates 0:00.

**NOTE:** The timer delay is up to a maximum of 15 hours. The timer function is not available for programs 9,11,13,14 or 15.

**WARNING:** Do not use the timer function when working with refrigerated ingredients such as eggs, milk, cream or cheese.

## HINTS AND TIPS

- After a power supply failure the ingredients will have to be discarded and you must start again with fresh ingredients.
- Place all recipe ingredients into the Baking Pan so that the yeast is not touching any liquid.
- When making bread dough, at the end of the program remove the dough from the Baking Pan. Shape according to the recipe, glaze and leave to rise before oven baking.
- Humidity can cause problems, therefore humidity and high altitudes require adjustments. For high humidity, add an extra tablespoon of flour if the consistency is not right. At high altitudes, decrease the yeast amount by approximately 1/4 teaspoon, and decrease the sugar and/or water or milk quantity slightly.
- When recipes call for a 'lightly floured surface' use about 1 to 2 tablespoons (tbsp) of flour. You may want to lightly flour your fingers or rolling pin as well for easier handling.
- If the dough you are rolling shrinks back, let it rest covered for a few minutes before rolling again.
- Dough may be wrapped in plastic and stored in the freezer for later use. Thaw and bring to room temperature before using.
- After 5 minutes of kneading, open the Lid and check the dough consistency. The dough should form a soft, smooth ball. If too dry, add liquid. If too wet, add flour (1/2 to 1 tablespoon at a time).
- Since homemade bread has no preservatives it stales more quickly than commercially made bread.
- Do not open the Lid whilst the Bread maker is operating as this will affect the quality of the bread, especially its ability to rise properly. Only open the Lid when the recipe needs you to add additional ingredients (see recipes).
- The Bread maker will work well in a wide range of temperatures, but there could be a difference in loaf size between a very warm room and a very cold room. We recommend the room temperature should be between 15°C and 34°C. All ingredients, and liquids (water or milk), should be warmed to room temperature 21°C. If ingredients are too cold, below 10°C, they will not activate the yeast. Hot liquids, above 40°C, may kill the yeast.

## MEASURING INGREDIENTS

The most important step when using your Bread maker is measuring your ingredients precisely and accurately. It is extremely important to measure liquid and dry ingredients properly or it could result in a poor baking result. Do not use standard kitchen teaspoons (tsp) or tablespoons (tbsp). The ingredients must also be added into the Baking Pan in the order in which they are given in each recipe. Liquid and dry ingredients should be measured as follows:

### Measuring Cup & Spoon

The cup is standard Australian cup volume which is equal to 240ml and is marked in 50ml increments, as well as standard cup divisions. The measuring spoon includes both a standard teaspoon (5ml) and tablespoon (15ml) end.

### Liquid Measurements

Use the Measuring Cup provided. When reading amounts, the measuring cup must be placed on a horizontal flat surface and viewed at eye level (not on an angle). The liquid level line must be aligned to the mark of measurement.

### Dry Measurements

Dry measurements must be done using the Measuring Cup provided or using a set of digital weighing scales. Dry measuring must be done by gently spooning ingredients into the Measuring Cup and then once filled, levelling off with a knife. Tapping the Measuring Cup will pack the ingredients and you will end up with more than is required. This extra amount could affect the balance of the recipe. Do not sift the flour, unless stated.

When measuring small amounts of dry or liquid ingredients there is one Measuring Spoon the following capacities - 1 tablespoon (tbsp) and 1 teaspoon (tsp). Measurements must be leveled off, not heaped as this small difference could throw out the critical balance of the recipe.

This machine requires that you carefully follow the recipe instructions. In basic cooking, normally 'a pinch of this and a dash of that' is fine, but not for bread makers. Using an automatic Bread Maker requires you to accurately measure each ingredient for best results.

- Always add ingredients in the order they are listed in the recipe.
- Please note that the measuring cups are based on 240ml.
- Accurate measuring of ingredients is vital. Do not use larger amounts.

## USING THE RIGHT INGREDIENTS

Flours, while visibly similar, can be very different by virtue of how they were grown, milled and stored. You may find that you will have to experiment with different brands of flour to help you make that perfect loaf. Storage is also very important, as all flours should be kept in an airtight container.

### All Purpose Flour/Plain Flour

All purpose flour is a blend of refined hard and soft wheat flours especially suitable for making cake. This type of flour should be used for recipes in the cake/quick bread section.

### Strong White Flour/Bread Flour

Bread flour is a high gluten/protein flour that has been treated with conditioners that give dough a greater suitability for kneading. Bread flour typically has a higher gluten concentration than All purpose flour; however, depending on different milling practices, this may vary. Strong plain flour or bread flour are recommended for use with this Bread maker.

### Wholewheat Flour/ Wholemeal Flour

Wholewheat flour/wholemeal flour is milled from the entire wheat kernel which contains the bran and germ and makes it heavier and richer in nutrients than white flour. Breads made with this flour are usually smaller and heavier than white loaves.

To overcome this wholewheat flour/wholemeal flour can be mixed with Bread flour or strong plain flour to produce a lighter textured bread.

### Self-Raising Flour

Self-raising Flour contains unnecessary leavening ingredients that will interfere with bread making. It is not recommended for use.

### Bran

Bran (unprocessed) & Wheat Germ are the coarse outer portions of the wheat or rye grains separated from flour by sifting or bolting. They are often added in small quantities to bread for nutritional enrichment, heartiness and flavour. They are also used to enhance the texture of bread.

### Oatmeal

Oatmeal comes from rolled or steel-cut oats. They are used primarily to enhance flavour and texture.

### Yeasts (Active Dry Yeast)

Yeast through a fermentation process produces gas (carbon dioxide) necessary to make the bread rise. Yeast must be able to feed on sugar and flour carbohydrates in order to produce this gas. There are three different types of yeast available: fresh, traditional dry active, and fast action. It is recommended that fast action yeast be used for the recipes in this book. Fresh or compressed cake yeast is not recommended as they will produce poor results. Store yeast according to manufacturers instructions. Ensure your yeast is fresh by checking its expiration date. Once a package of yeast is opened it is important that the remaining contents be immediately resealed and refrigerated for future use. Often bread or dough, which fails to rise is due to stale yeast being used. The following test can be used to determine whether your yeast is stale and inactive:

1. Place half a cup of lukewarm water into a small bowl or cup.
2. Stir 1 tsp. of sugar into the water then sprinkle 2 tsp. of yeast over the surface.
3. Place bowl or cup in a warm area and allow to sit for 10 minutes undisturbed.
4. The mixture should foam and produce a strong yeast aroma. If this does not occur, discard mixture and start again with another packet of dried yeast.

### Sugar

Sugar is important for the colour and flavour of breads. It is also food for the yeast as it is part of the fermentation process. Use caster sugar or soft brown sugar according to the recipe. **Artificial sweeteners cannot be used as a substitute for sugar as the yeast will not react properly with them.**

### Salt

Salt is necessary to balance the flavour of breads and cakes, as well as for the crust colour that develops during baking. Salt also limits the growth of yeast so the amounts shown in the recipes should not be increased. For dietary reasons it may be reduced, although results may be affected.

### Eggs

Eggs add richness and a velvety texture to bread doughs and cakes. Recipes supplied use medium eggs.

### Sunflower Oil

'Shortens' or tenderises the texture of yeast breads. Butter or margarine can be used as a substitute. If butter or margarine is used directly from the refrigerator it should be softened first for easier blending during the mixing cycle.

### Baking Powder

Baking powder is a raising agent used in cakes. This type of raising agent does not require rising time before baking as the chemical reaction works when liquid ingredients are added.

### Bicarbonate Of Soda

Bicarbonate of soda is another raising agent, not to be confused or substituted with baking powder. It also does not require rising time before baking as the chemical reaction works during the baking process.

### Liquids/Milk

Liquids such as milk or powdered milk and water, can be used when making bread. Milk will improve flavour, provide a velvety texture and soften the crust, while water alone will produce a crisp crust. Some recipes include juice (orange, apple, etc) to be added as a flavour enhancer.

Note: For most recipes we suggest the use of dry (powdered) skimmed milk.

If you wish to use milk instead of dried milk powder for bread making you can. Milk should be at the recommended 21-28°C.

Pour an amount of milk into a measuring jug, but make sure you then add enough water to make it up to the quantity (of water) in the recipe you're following.

So for example, if the recipe requires 360ml water, you can use 280ml milk with 80ml water or if preferred 360ml milk.

To balance the flavour of the bread, for every tbsp of milk powder in the recipe, use the equivalent amount of milk in the table below then add water to make up the total recipe quantity.

## OTHER INGREDIENTS

Milk Powder (tbsp)	Milk Equiv. (ml)
• 1	• 70
• 1 1/2	• 105
• 2	• 140
• 2 1/2	• 180
• 3	• 210
• 3 1/2	• 250
• 4	• 280

Give your just baked bread a professional finish. Select one of the following special glazes to enhance your bread.

### Egg Glaze

Beat 1 egg and 1 tablespoon of water together, brush generously.

Note: apply only to doughs before baking.

### Melted Butter Crust

Brush melted butter over just baked bread for a softer, tender crust.

### Milk Glaze

For a softer, shiny crust, brush just baked bread with milk or cream.

### Sweet Icing Glaze

Mix 1 cup sifted icing sugar with 1 to 2 tablespoons of milk to make a glaze consistency and drizzle over raisin bread or sweet breads.

### Poppy/Sesame/Caraway Seeds/Oatmeal

Sprinkle your choice of these seeds generously over just glazed bread.

### Yoghurt

To make yogurt, natural bio live yogurt must be used in the recipe. Make sure it is fresh by checking the use by date. Pasteurised natural yogurt is not suitable.

## RECIPES

With a Bread Maker, even the most inexperienced baker can achieve the satisfying experience of baking a loaf of bread. Inside the Bread Maker, the dough is mixed, kneaded proved and baked without you being present.

The Bread Maker can also just prepare dough, and when it's ready, you shape, allow to rise and bake in a conventional oven. The recipes on the following pages are 'tailored' for this Bread Maker.

Each recipe features ingredients for that particular loaf of bread, and each was tested in our machines.

It is extremely important not to exceed the amounts of flour specified in each of the recipes as this could result in unsatisfactory baking performance. When creating your own yeast bread recipes or baking an old favourite, use the recipes supplied as a guide for adapting your own recipes.

## BASIC BREAD (PROG 1)

Ingredients	Loaf Size	900g	1.15kg	1.35kg
• Water		• 340ml	• 380ml	• 420ml
• Oil		• 2 tbsp	• 3 tbsp	• 4 tbsp
• Salt		• 1 tsp	• 1½ tsp	• 2 tsp
• White Bread Flour		• 600g	• 675g	• 750g
• Sugar		• 1½ tbsp	• 2 tbsp	• 3 tbsp
• Yeast		• 1 tsp	• 1 tsp	• 1 tsp

## FRENCH BREAD (PROG 2)

Ingredients	Loaf Size	900g	1.15kg	1.35kg
• Water		• 340ml	• 390ml	• 440ml
• Oil		• 2 tbsp	• 3 tbsp	• 4 tbsp
• Salt		• 1 tsp	• 2 tsp	• 2 tsp
• White Bread Flour		• 600g	• 690g	• 780g
• Sugar		• 1½ tbsp	• 1½ tbsp	• 2 tbsp
• Yeast		• 1 tsp	• 1 tsp	• 1 tsp

## WHOLE WHEAT BREAD (PROG 3)

Ingredients	Loaf Size	900g	1.15kg	1.35kg
• Water		• 370ml	• 440ml	• 510ml
• Oil		• 2 tbsp	• 3 tbsp	• 4 tbsp
• Salt		• 1 tsp	• 1½ tsp	• 2 tsp
• Whole Wheat Flour		• 300g	• 350g	• 400g
• Brown Sugar		• 1½ tbsp	• 2½ tbsp	• 3 tbsp
• Yeast		• 1¼ tsp	• 1¼ tsp	• 1¼ tsp

## SWEET BREAD (PROG 4)

Ingredients	Loaf Size	900g	1.15kg	1.35kg
• Water		• 340ml	• 380ml	• 420ml
• Oil		• 3 tbsp	• 3 tbsp	• 4 tbsp
• Salt		• 1 tsp	• 1½ tsp	• 2 tsp
• White Bread Flour		• 600g	• 675g	• 750g
• Sugar		• 4 tbsp	• 5 tbsp	• 6 tbsp
• Yeast		• 1 tsp	• 1 tsp	• 1 tsp

## LOW CARB BREAD (PROG 5)

Ingredients	Loaf Size	900g	1.15kg	1.35kg
• Eggs		• 3	• 4	• 4
• Butter (melted)		• 75g	• 100g	• 100g
• Quark		• 150g	• 200g	• 250g
• Full Fat Milk		• 200ml	• 250ml	• 300ml
• Almond Flour		• 100g	• 150g	• 200g
• Salt		• 1 tsp	• 1 tsp	• 1 tsp
• Lemon Extract		• 2 ml	• 2 ml	• 2 ml
• Almonds		• 100g	• 150g	• 200g
• Baking Powder		• 4 tsp	• 8 tsp	• 8 tsp

## GLUTEN FREE BREAD (PROG 6)

Ingredients	Loaf Size	900g	1.15kg	1.35kg
• Water		• 340ml	• 380ml	• 420ml
• Oil		• 2 tbsp	• 3 tbsp	• 4 tbsp
• Salt		• 1 tsp	• 1½ tsp	• 2 tsp
• Gluten Free Flour		• 600g	• 675g	• 750g
• Sugar		• 1½ tbsp	• 2 tbsp	• 3 tbsp
• Yeast		• 1½ tsp	• 1½ tsp	• 1½ tsp

## SUPER RAPID (PROG 7)

Ingredients	Loaf Size	900g	1.15kg	1.35kg
• Water		• 320ml	• 360ml	• 400ml
• Oil		• 5 tbsp	• 6 tbsp	• 7 tbsp
• Salt		• 1 tsp	• 1½ tsp	• 2 tsp
• Flour		• 600g	• 675g	• 750g
• Sugar		• 1½ tbsp	• 2 tbsp	• 3 tbsp
• Yeast		• 1¼ tsp	• 2 tsp	• 1½ tsp

## CAKE (PROG 8)

Ingredients	Loaf Size	900g	1.15kg	1.35kg
• Butter		• 6 tbsp	• 8 tbsp	• 10 tbsp
• Sugar		• 6 tbsp	• 8 tbsp	• 10 tbsp
• Egg		• 4	• 5	• 6
• Self Raising Flour		• 150g	• 225g	• 300g
• Flavour Essence		• 1tsp	• 1 tsp	• 1 1/3 tsp
• Lemon Juice		• 1 tbsp	• 1 1/3 tbsp	• 1¾ tbsp
• Yeast		• 1 tsp	• 1 1/3 tsp	• 1½ tsp

## DOUGH (PROG 10)

### Ingredients

• Water	• 270ml
• Oil	• 2 tbsp
• Salt	• 1 tsp
• White Bread Flour	• 450g
• Sugar	• 2 tbsp
• Yeast	• 1 tsp

## PASTA DOUGH (PROG 11)

### Ingredients

• Water	• 300ml
• Oil	• 2 tbsp
• Salt	• 1 tsp
• Flour	• 500g
• Sugar	• 2½ tbsp
• Yeast	• 1 tsp

## PIZZA DOUGH (PROG 12)

### Ingredients

• Water	• 270ml
• Olive Oil	• 2 tbsp
• Salt	• ¼ tsp
• Flour	• 450g
• Sugar	• 2½ tbsp
• Yeast	• 1 tsp

## YOGURT (PROG 13)

### Ingredients

---

- |                                   |         |
|-----------------------------------|---------|
| • Whole Milk                      | • 900ml |
| • Acidophilus milk or Acidophilus | • 100ml |
- 

## JAM (PROG 14)

### Ingredients

---

- |                       |          |
|-----------------------|----------|
| • Strawberry (mashed) | • 4 cups |
| • Jam Sugar           | • 500g   |
| • Lemon Juice         | • 40ml   |
-

## RECIPE BAKING TIMES

Program	Crust	Loaf Size	Total Time	Preheat	Knead 1	Rise 1	Knead 2	Rise 2	Rise 3	Bake	Add Fruit	Keep Warm
1. Basic	Light Medium Dark	900g	3:00	15	13	25	12	30	30	55	2:00	60
		1150g	3:05	15	13	25	12	30	30	60	2:05	60
		1350g	3:15	20	13	25	12	30	30	65	2:10	60
	Rapid	900g	2:15	-	13	10	9	18	30	55	1:48	60
		1150g	2:20	-	13	10	9	18	30	60	1:53	60
		1350g	2:25	-	13	10	9	18	30	65	1:58	60
2. French	Light Medium Dark	900g	3:10	10	12	20	15	38	35	60	60	60
		1150g	3:15	10	12	20	15	38	35	65	2:26	60
		1350g	3:25	15	12	20	15	38	35	70	2:31	60
	Rapid	900g	2:20	-	13	10	9	18	30	60	1:53	60
		1150g	2:25	-	13	10	9	18	30	65	1:58	60
		1350g	2:30	-	13	10	9	18	30	70	2:03	60
3. Whole Wheat	Light Medium Dark	900g	3:20	15	12	30	15	38	35	55	2:16	60
		1150g	3:25	15	12	30	15	38	35	60	2:21	60
		1350g	3:35	20	12	30	15	38	35	65	2:26	60
	Rapid	900g	2:25	-	13	10	9	23	35	55	1:58	60
		1150g	2:30	-	13	10	9	23	35	60	2:03	60
		1350g	2:35	-	13	10	9	23	35	65	2:08	60
4. Sweet	Light Medium Dark	900g	2:55	10	12	25	13	35	30	50	2:01	60
		1150g	3:00	10	12	25	13	35	30	55	2:06	60
		1350g	3:10	15	12	25	13	35	30	60	2:11	60
	Rapid	900g	2:10	-	12	10	10	18	30	50	1:44	60
		1150g	2:15	-	12	10	10	18	30	55	1:49	60
		1350g	2:20	-	12	10	10	18	30	60	1:54	60
5. Low Carb	Light Medium Dark	900g	3:09	15	20	15	22	15	22	90	1:59	60
		1150g	3:21	15	21	15	24	17	24	85	2:10	60
		1350g	3:33	15	22	15	26	19	26	90	2:21	60

Program	Crust	Loaf Size	Total Time	Preheat	Knead 1	Rise 1	Knead 2	Rise 2	Rise 3	Bake	Add Fruit	Keep Warm
6. Gluten Free	Light Medium Dark	900g	3:40	15	12	20	13	50	50	60	2:48	60
		1150g	3:45	15	12	20	13	50	50	65	2:53	60
		1350g	3:55	20	12	20	13	50	50	70	2:58	60
7. Super Rapid	Light Medium Dark	900g	1:15	-	8	-	7	-	20	40	-	60
		1150g	1:18	-	8	-	7	-	20	43	-	60
		1350g	1:20	-	8	-	7	-	20	45	-	60
8. Cake	Light Medium Dark	900g	1:30	-	25	-	-	-	-	65	-	60
		1150g	1:35	-	25	-	-	-	-	70	-	60
		1350g	1:40	-	25	-	-	-	-	75	-	60
9. Kneading	-	-	0:10	-	10	-	-	-	-	-	-	
10. Dough	-	-	1:40	-	12	10	8	25	45	-	-	
11. Pasta Dough	-	-	0:15	-	15	-	-	-	-	-	-	
12. Pizza Dough	-	-	0:45	-	15	10	10	10	-	-	-	
13. Yoghurt	-	-	8:00 - 12:00	-	-	8:00-12:00	-	-	-	-	-	
14. Jam	-	-	1:20	-	15	-	-	-	-	45	-	Rest 20
15. Bake	L/M/D	-	1:00	-	-	-	-	-	-	60	-	60
16. Homemade	Default Setting	-	3:05	15	13	25	12	30	30	60	-	60

The delay timer is available on all programs except 9, 11, 13, 14 and 15. Maximum delay is 15 hours

### Bread Sinks in the centre

Too much liquid or liquid too warm.	Measure ingredients accurately. Use liquids at temperatures between 21°C and 28°C.
Salt was not added, causing bread to over rise and collapse.	Measure ingredients accurately.
Too much yeast was added.	Measure ingredients accurately, if problem persists, reduce yeast by 1/4 teaspoon.
High humidity and hot ambient temperatures can cause bread to over rise and collapse.	Bake during the coolest part of the day, Try reducing the yeast by 1/4 teaspoon or use liquids direct from the refrigerator. Do not use the timer function.
High altitudes can cause the bread to over rise and then collapse during baking.	Try reducing the yeast by 1/4 teaspoon.
Lid (3) is open during baking.	Do not open the lid during baking.

### Bread did not rise enough

Not enough yeast was added.	Measure ingredients accurately.
Yeast is outdated or inactive.	Never use outdated yeast. Store in a cool, dark place.
Too little sugar was added.	Measure ingredients accurately.
Too much salt was added, reducing the action of the yeast.	Measure ingredients accurately.
Water was too hot and killed the yeast.	Use liquids at temperatures between 21°C and 28°C.
Yeast has been activated before program has started.	Take care that yeast does not come in contact with liquid before program has started.

### Bread dry with dense texture

Not enough liquid added.	Measure ingredients accurately.
Flour may have passed the use by date, or be dry causing wet/dry imbalance.	Try increasing liquid by 1 tbsp at a time.

## Bread rises too much

High humidity and hot ambient temperatures can cause bread to over rise.

Bake during the coolest part of the day. Try reducing the yeast by 1/4 teaspoon or use liquids directly from the refrigerator. Do not use the Timer function.

---

Too much yeast.

Measure ingredients accurately.

---

Too much liquid.

Measure ingredients accurately.

---

Hot liquids accelerated the yeast action.

Use liquids at temperatures between 21°C and 28°C.

---

Too much flour or not enough salt.

Measure ingredients accurately.

## Bread under baked with soggy centre

Too much liquid from fresh or canned fruit.

Always drain liquids well as specified in the recipe. Water may have to be reduced slightly.

---

Large amounts of rich ingredients like nuts, butter, dried fruits, syrups and grains will make dough heavy. This will slow down the rising and prevent the bread from baking through.

Measure ingredients accurately. Never exceed the amounts in the recipe.

## Bread over browned

Too much sugar.

Measure ingredients accurately.

---

Crust colour set too high.

Set crust colour to light.

## Bread has large holes in texture.

Water was too hot and killed the yeast.

Use liquids at temperatures between 21°C and 28°C

---

Too much liquid.

Measure ingredients accurately.

---

Too much yeast.

Measure ingredients accurately.

---

High humidity and hot ambient temperatures increase yeast activity.

Bake during the coolest part of the day. Try reducing the yeast by 1/4 teaspoon or use liquids direct from the refrigerator. Do not use the timer function.

---

Bread surface is sticky.

Bread was left in the machine too long and condensation collected on the baking pan. Whenever possible, remove bread from the baking pan and cool on a wire rack before keep warm period ends.

---

The wet/dry balance of the ingredients may be incorrect.

Measure ingredients accurately.

## ERROR CODES

**WARNING:** If the below error codes are shown on the display, please follow the steps below.

If “HHH” is displayed after the program has started, it means that the temperature inside of bread pan is too high. You should stop the program and unplug from the power outlet immediately. Open the lid and let the machine cool down completely before using again.

If “LLL” is displayed after the program has started, it means that the temperature inside of bread pan is too low - which can damage the bread maker. If this happens, stop the program and unplug from the power outlet and move the unit to a warmer environment and wait until the ingredients unfreeze.

If “EE0” is displayed, switch the unit off and unplug from the power outlet. Wait 2 minutes, then reconnect to a power outlet and turn the unit On. If the error message is still displaying, please contact customer service.

## CARE & CLEANING

**Caution:** To prevent electrical shock, unplug the Bread Maker before cleaning. Always wait until the Bread maker has cooled.

**IMPORTANT:** Do not immerse or splash either the Main Unit or Lid in any liquid as this may cause damage and/or electric shock.

**Exterior:** Wipe the lid and outer body of the unit with a damp cloth or slightly dampened sponge.

**Interior:** Use a damp cloth or sponge to wipe the interior of the Bread Maker.

**Baking pan:** Clean the Baking Pan with warm soapy water. Avoid scratching the non-stick surface. Dry it thoroughly before placing it back in the Main Unit.

Do not wash the Baking Pan, Measuring Cup, Measuring Spoon or Kneading Blades in the dishwasher.

Do not soak the Baking Pan for long periods as this could interfere with the working of the drive shaft.

If the Kneading Blade becomes stuck in the Baking Pan, pour hot water over it and allow to soak for 30 minutes. This will enable you to remove the Kneading Blade more easily.

Be sure the Bread maker is completely cooled before storing away.

Do not use any of these when cleaning: Paint thinner; Benzine; Steel wool pads; Polishing powder; Chemical dust cloth

## NON-STICK FINISH

**Avoid damaging the coating. Do not use metal utensils such as spatulas, knives or forks.**

**The coating may change colour in time, this is only caused by moisture and steam and will not affect the performance of the unit or quality of your bread.**

**If the retainer in the kneading paddle is clogged, you can clean it carefully with a wooden skewer.**

**Keep the Air Vents and openings clear of dust.**

## MAINTENANCE

**If the unit fails to operate efficiently, is broken or other problems arise, unplug and do not operate.**

**Ask for advice by calling your local after sales service agent or the Customer Care Centre on 1300 556 816 (AU) / 0800 666 2824 (NZ).**

## WARRANTY

**Please refer to the warranty card in the box for warranty information. For any troubleshooting advice, please contact the relative Customer Care Centre below.**

**Glen Dimplex Australia Pty Ltd  
1340 Ferntree Gully Road,  
Scoresby 3179, Victoria  
Australia  
Ph: 1300 556 816**

**Glen Dimplex New Zealand Ltd  
38 Harris Road, East Tamaki,  
Auckland 2013  
New Zealand  
Ph: 0800 666 2824**







Recycling: Do not dispose of electrical appliances as unsorted municipal waste. Use separate collection facilities. Contact your local government for information regarding the collection systems available. If electrical appliances are disposed of in landfills or dumps, hazardous substances can leak into the ground water, polluting the food chain and damaging health and wellbeing.

**morphy richards®**

Glen Dimplex Australia Pty Ltd  
1340 Ferntree Gully Road  
Scoresby VIC 3179  
Phone: 1300 556 816  
Email: [sales@glendimplex.com.au](mailto:sales@glendimplex.com.au)  
Web: [www.morphyrichards.com.au](http://www.morphyrichards.com.au)

© Glen Dimplex Australia. All rights reserved. Material contained in this publication may not be reproduced in whole or in part, without prior permission in writing of Glen Dimplex Australia.