



blaze | **Z3**

OPERATING INSTRUCTIONS

Contemporary Styled Wood Heaters



BLAZE Z3 LEGS



BLAZE Z3 ASH



BLAZE Z3 WOODSTACKER



Glen Dimplex Australia supports the Australian wood heating industry through its membership of the AHHA.

VERSION 1.1

TABLE OF CONTENTS

USER INSTRUCTIONS

1. Introduction	2
1.1. Air Controls	3
1.2. Door Handle	3
1.3. Wood Storage Compartment	3
2. Using Appliance for the First Time	3
3. Recommended Fuels	3
4. Lighting the Fire	4
5. Running the Appliance	4
5.1. Maximum Heat Output	4
5.2. Low Heat Output	4
5.3. Reload with More Wood	4
6. Burning Tips	5
6.1. Fuel Quality	5
6.2. Flue Draught	5
7. Ash Removal	5
7.1. Z3 Ash	5
8. Flue/Chimney Fire	6
9. Cleaning Paintwork and Glass	6
10. Cleaning the Flue	6
11. Troubleshooting Tips	7
11.1. Glass in Door Blackening	7
11.2. Trouble Starting the Fire	7
11.3. Burning Too Quickly	7

MAINTENANCE AND SERVICING

1. Replacement of Fire Bricks	8
2. Replacement of Baffle	8
3. Removing the Door	9
4. Adjusting the Door Hinge	9
5. Adjusting the Door Latch	10
6. Fitting New Door Glass	10
7. Fitting a New Door Seal	11
8. Warranty	12
9. Replacement Spare Parts List	14

User Instructions

1. INTRODUCTION

Before use of this appliance please read these instructions fully.

WARNING: ANY MODIFICATION OF THE APPLIANCE THAT HAS NOT BEEN APPROVED IN WRITING BY THE TESTING AUTHORITY IS CONSIDERED AS BREACHING AS/NZS 4013.

WARNING: DO NOT USE FLAMMABLE LIQUIDS OR AEROSOLS TO START OR REKINDLE THE FIRE.

WARNING: DO NOT USE FLAMMABLE LIQUIDS OR AEROSOLS IN THE VICINITY OF THIS APPLIANCE WHEN IT IS OPERATING.

WARNING: DO NOT STORE FUEL WITHIN HEATER INSTALLATION CLEARANCES.

WARNING: WHEN OPERATING THIS APPLIANCE AS AN OPEN FIRE USE A FIRE SCREEN.

WARNING: OPEN AIR CONTROL BEFORE OPENING DOOR.

WARNING: DO NOT BURN WOOD THAT IS PAINTED; OR IS COATED WITH PLASTIC; OR HAS BEEN TREATED WITH ANY CHEMICAL.

CAUTION: THIS APPLIANCE SHOULD NOT BE OPERATED WITH CRACKED GLASS.

CAUTION: THIS APPLIANCE SHOULD BE MAINTAINED AND OPERATED AT ALL TIMES IN ACCORDANCE WITH THESE INSTRUCTIONS.

The appliance or flue system should not be modified in any way without the written approval of the manufacturer.

Extraction fans or rangehoods must not be placed in the same room or space, as this can cause appliance to emit smoke into the room.

1.1. AIR CONTROLS

The Blaze Z3 range features a single air control system. It is designed to introduce oxygen into the base of the fire, controlling the rate of combustion of the wood as well as the oxygen being drawn into the upper firebox where combustion of the gases occurs.

The air control is operated by sliding the tab handle located on the top right of the heater. Sliding all the way to the right offers maximum burn rate, while all the way to the left offers minimum burn rate.

Secondary air holes in the rear and sides of the firebox provide additional oxygen for a more complete combustion of the gases released from the burning wood.

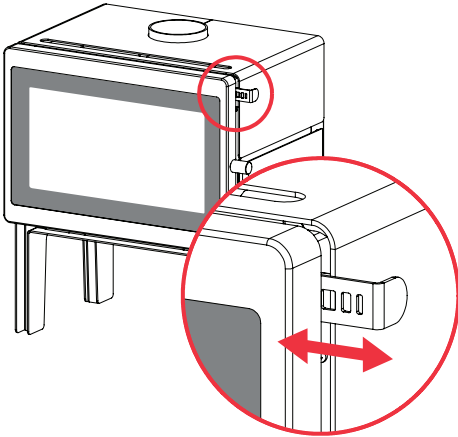

1.2. DOOR HANDLE

Warning: the door handle may get hot if appliance has been left in High burn setting for an extended period of time. A stainless steel handle extension is supplied with the heater that can be inserted in the end of the door handle when opening and closing if too hot to handle.

1.3. WOOD STORAGE COMPARTMENT

Warning: the Blaze Z3 Woodstacker features a storage area for a small amount of firewood. Do not overload this compartment - ensure that there

is at least a 5mm gap to the ceiling of the unit, and no combustible fuel forward of the storage area.

2. USING APPLIANCE FOR THE FIRST TIME

The first few times the appliance is lit, it will give off some odorous fumes. This is caused by the paint curing.

Do not touch the paint work while it is curing otherwise it can leave a permanent mark on the appliance.

Once the paint has cured it will not re-occur.

Keep the room well ventilated until these fumes have cleared.

3. RECOMMENDED FUELS

Burn only seasoned hardwood timber with a moisture content of less than 20%. Newly cut wood should be allowed to dry/season for 12 to 18 months before use.

Wood should be stored in an environment protected from the weather to minimise any potential moisture content.

For best results, wood should not exceed 270mm in length and 150mm in diameter. Any larger, and the appliance will not operate at its optimum. It is better to burn several smaller pieces of wood than one large single piece.

Poor quality timber:

- Causes low combustion efficiency
- Produces poor emissions (smoky)
- Results in additional buildup of creosote (soot) in the flue which will then require regular cleaning and may result in a flue fire.

Do not burn painted, impregnated/treated wood, manufactured board products or pallet wood.

4. LIGHTING THE FIRE

1. Place firelighters or paper and dry kindling wood in the base of the firebox.
2. Light the paper or firelighters.
3. Open the air control located on the top right corner of the appliance by sliding to the right.
4. If necessary, leave the door slightly open as the fire establishes and the glass warms to avoid the build-up of condensation.
5. Add larger pieces of wood. Too many logs may smother the fire.
6. Close the door.

Do not leave fire unattended while door is open.

5. RUNNING THE APPLIANCE

5.1. MAXIMUM HEAT OUTPUT

After establishing the fire and loading it with larger pieces of wood, leave it running with the air slide fully open (slid all the way to the right).

This setting will generate maximum heat output.

Running the appliance with the door open will not produce maximum heating in the room, as it will draw a lot of already warmed air out of the room.

Do not overload firebox with fuel.

Note that this setting is not the most energy efficient as some heat is lost up the flue instead of being transferred into the room. However, once the fire is established, particulate emissions will be very low in this setting.

5.2. LOW HEAT OUTPUT

The heat output of the appliance can be reduced by closing the air slide, which will restrict the oxygen supplied to the fire and slow down the rate at which the wood burns.

This setting provides the best energy efficiency as the wood burns for longer. However, if not operated correctly it may worsen emissions.

Prior to closing the air slide, ensure that the fire is burning briskly. This may require opening the air slide fully for 5-10mins before shutting down.

For the optimum between clean burning and getting the best in efficiency, from the fully closed position, open the air slide 4-5mm.

The air slide can be adjusted to any position depending on desired heat output versus burn time.

5.3. RELOAD WITH MORE WOOD

1. Open air slide before opening door.
2. Rake / break up any existing coals.
3. Load the wood with the length oriented front to back.
4. Better results will be achieved by loading several smaller pieces of wood rather than one large piece.
5. Close door with air slide fully open, and leave for a minimum of 10 minutes to allow the fresh wood to catch.
6. After 10 or more minutes, the top air slide can be adjusted to desired heat setting.

6. BURNING TIPS

6.1. FUEL QUALITY

Use wood with a moisture content of less than 20%. Logs should not feel moist or damp, or have moss and fungal growths.

Symptoms related to wet wood:

- Difficulty starting and keeping a fire burning well.
- Smoke and only small flames.
- Dirty glass and/or fire bricks.
- Rapid creosote build-up in the flue/chimney.
- Low heat output.
- Short burn times, and blue/grey smoke from the flue/chimney outlet.

Run appliance at high heat output for a short period each day to avoid large build-up of tars and creosote within the appliance and flue.

6.2. FLUE DRAUGHT

The flue has two main functions:

1. To safely remove smoke, gases and fumes from the appliance.
2. To provide a sufficient amount of draught (suction) in the appliance to ensure the fire keeps burning.

Draught is caused by the rising hot air in the flue when the fire has been lit.

The position, height and size of the flue can affect the performance of the flue draught. Refer to installation guide for details on flue installation.

Factors affecting the flue draught include:

- Insufficient flue height
- Trees or other buildings nearby causing turbulence

- High and gusty winds
- Outside temperature and weather conditions
- Blocked flue

For advice on the correction of persistent flue problems consult your supplier/installer.

7. ASH REMOVAL

Depending on the type of wood burnt and frequency, the ashes will need removing every 2 to 6 weeks.

Excess ashes should be removed when necessary, placed in a non-combustible container with a tightly fitting lid and moved outdoors immediately to a location clear of combustible materials.

7.1. Z3 ASH

The Z3 Ash model has a built in ash pan. Ash can be emptied directly into the ash pan by removing the ash plug in the base of the firebox.

Wait until the fire has gone out completely and the unit is cool to the touch before attempting to clean out ash and coals.

1. Using supplied tool, remove ash plug from the firebox as shown. Lift up and out of firebox, and set plug and middle brick aside.

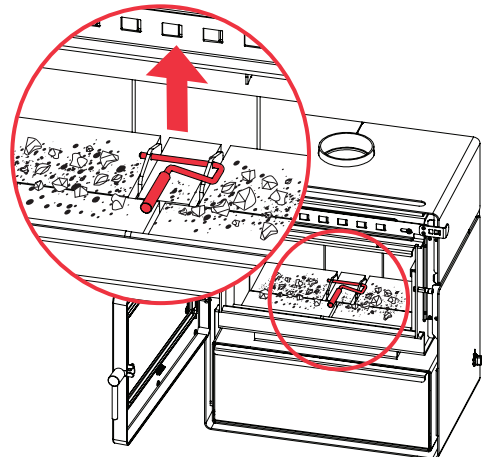

- Using a suitable hand broom, brush loose ash and coals into the ash drain.

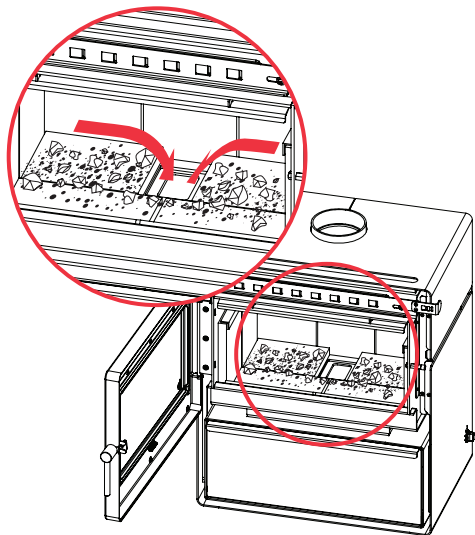

- Open ash door and remove ash pan. Close the sliding lid on top of the ash pan while carrying the pan to your bin.

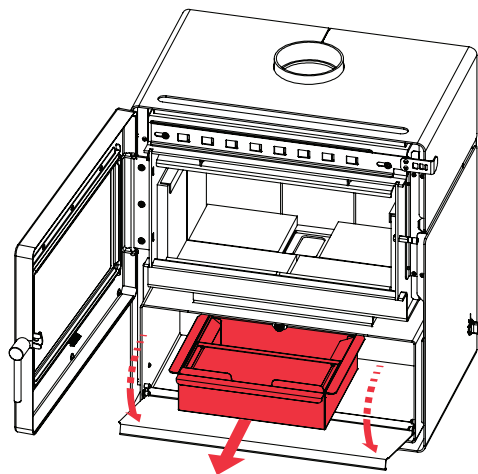

- Empty ash pan. Then, repeat steps 1 to 3 in reverse order to reinstall ash pan and ash plug. The lid on the ash pan will slide open upon being replaced under the firebox.

8. FLUE/CHIMNEY FIRE

If a flue/chimney fire occurs:

- Shut air slide control fully to smother the fire
- Do not use the appliance after a flue fire until an accredited installer has assessed the cause and any resultant damage.

9. CLEANING PAINTWORK AND GLASS

The appliance, when cool, can be cleaned with a damp cloth.

Over the years, the black paint will fade and can be touched up with Stove Bright metallic black paint.

To clean the glass, we recommend using a household window cleaner or general purpose cleaner with a soft cloth. Do not use abrasive cleaner or scourer pads.

10. CLEANING THE FLUE

Check inside of flue prior to each season for any build-up of creosote (wood tar). To do this:

- First remove the baffle (refer to "2. Replacement of Baffle" under Maintenance & Servicing section).
- Using a small mirror and torch hold the mirror on an angle below the flue with the torch shining at it and look for black creosote build-up. A fine black powdery layer is normal, but if built up layers of creosote can be seen, then the flue needs cleaning.
- Refit the baffle if no cleaning is required.

To clean the flue:

- A flue cleaning brush can be purchased from most wood heater retail outlets or large hardware stores.
- The objective is to pull the brush down through the flue.
- With the baffle removed, tie a rope to one

end of the brush, and drop the rope from the top (outside on top of the roof) down the flue.

4. Grab the end of the rope inside the firebox and pull the brush through.
5. Check the inside of the flue with the mirror and torch. Repeat if necessary.
6. Once clean, remove any excess creosote from the firebox and replace the baffle.

Check flue integrity by checking that the 900mm flue sections have not separated at the joins.

Alternatively, get a flue cleaning service to do the job for you (it's a dirty job).

11. TROUBLESHOOTING TIPS

11.1. GLASS IN DOOR BLACKENING

This can have several possible causes:

- Burning unseasoned wood — if the wood is too wet, it will cause the glass to blacken.
- Appliance operated at low temperature — after an overnight burn where the air slide control has been fully closed, the glass may have blackened. When the fire is re-stoked and burning on the high heat setting, the blackened glass should self-clean.
- Problems with the flue — insufficient flue draught can cause the glass to blacken. If the flue is too short, not properly insulated, or in a position that results in a downdraught, then there will be insufficient flue draught. Contact the installer should this happen.

11.2. TROUBLE STARTING THE FIRE

If all ash has been removed from the firebox, it can upset the supply of air to the base of the fire. When cleaning out the firebox, retaining some ash can make it easier to start the fire next time.

11.3. BURNING TOO QUICKLY

If you find that the heater is burning through wood too quickly, see below:

1. Latch needs adjustment (refer to "4. Adjusting the Door Latch")
2. Door seal needs replacing (refer to "7. Fitting a New Door Seal")
3. Baffle needs replacing (refer to "2. Replacement of Baffle")

Maintenance and Servicing

1. REPLACEMENT OF FIRE BRICKS

The purpose of the firebricks in the appliance is to increase thermal mass and to guarantee the longevity of the steel firebox. Over time the firebricks may become cracked and crumble away. If so, they should be replaced.

To replace the firebricks:

1. Move any ash away from the bricks.
2. Remove the brick retainer and the bricks.
3. Replace with new bricks, and refit the retainer which hold the bricks in place.

Z3 Woodstacker/Legs bricks layout:

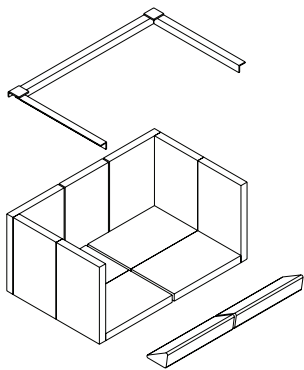

Z3 Ash bricks layout:

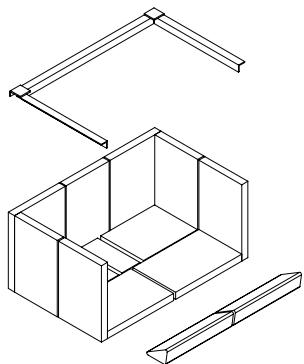

2. REPLACEMENT OF BAFFLE

The 25mm thick vermiculite baffle helps to retain the heat in the firebox by lengthening the path of the flames, so that they do not go straight up the flue.

Over time, the baffle may begin to deteriorate a little due to the excessive heat. This will not affect the way the fire burns.

Eventually the baffle will burn through (5+ years) and if so will need to be replaced.

To replace the baffle:

1. Remove the front baffle retainer.
2. Shift the baffle to the right of the heater, lifting the baffle up on the right side.
3. With the right side of the baffle raised above the right baffle rail, angle the left side of the baffle downwards to clear the left baffle rail.
4. Remove baffle from heater. Ensure rear retainer is installed on new baffle. Repeat steps 1 to 3 in reverse to install new baffle.

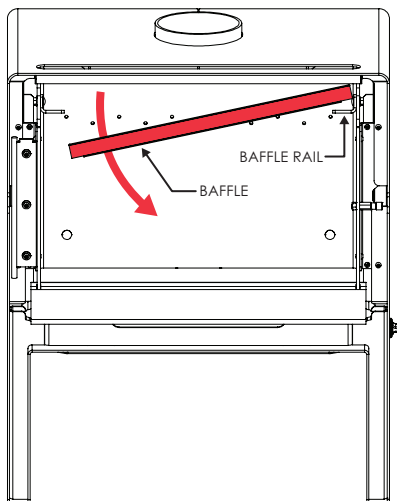

3. REMOVING THE DOOR

To remove the door:

1. Open the door all the way.
2. Lift the door up and over the top end of the vertical hinge rod.
3. Lower the door and slide off the bottom end of the hinge rod.

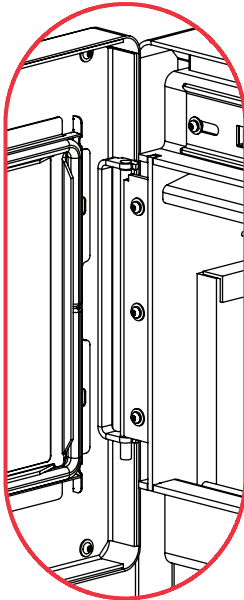
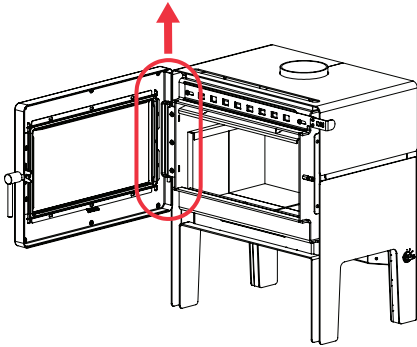

4. ADJUSTING THE DOOR HINGE

Over time the screws securing the door hinge plate to the heater may loosen resulting in the door dropping, i.e. visually appears on slight angle and no longer perfectly horizontal. This can result in poor latch feel, a loose door seal and unnecessary amounts of oxygen entering the firebox and wood burning too quickly.

To fix this and reposition the door:

1. With the supplied 4mm hex key, loosen the three screws on the hinge plate.
2. With the door 90% closed, slowly lift the bottom right corner of the door until the door is horizontal.
3. Keeping the door in that position relative to the hinge, open it and tighten the screws until firm.
4. Close the door to 90% again and make any final adjustments up or down by tapping the door on the right hand side until it appears parallel relative to the top and bottom surfaces of the heater.
5. Open door again and tighten screws fully.

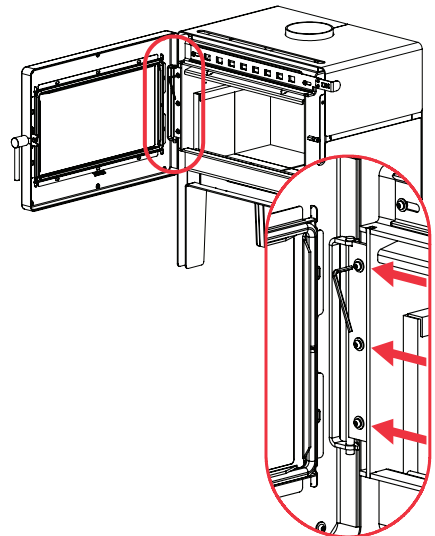

5. ADJUSTING THE DOOR LATCH

Over time, the door seal can become compressed, resulting in a less than adequate seal between the door and the front edge of the firebox. For example, if the wood burns unusually fast even with the air slide shut, it may mean that there is an air leak around the door.

In this situation, the door seal does not necessarily need replacing — adjustment of the latch can tighten the seal.

To adjust the door latch:

1. Using the supplied spanner, loosen the M8 hex nut inside the firebox.
2. Slide the latch inwards 1-2mm and retighten the M8 hex nut.
3. Close the door and test the tightness of the latch. If too tight or not tight enough, readjust until adequate latching pressure is achieved.

If the door is still not latching adequately – replace the door seal.

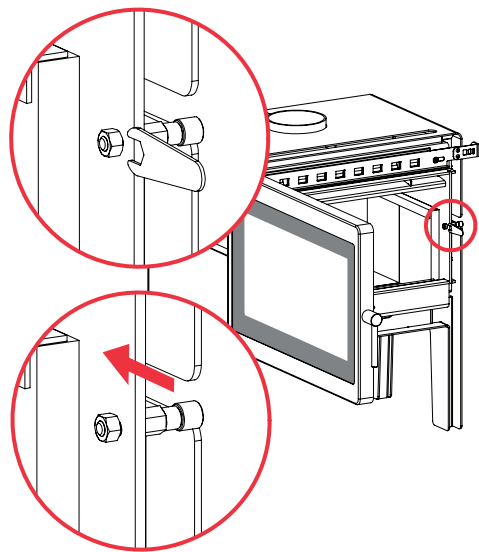

6. FITTING NEW DOOR GLASS

This task may be easier with the door removed from the heater and laid flat on a workbench.

To replace the door glass:

1. Carefully place the door glass side down on a work-bench. Using 4mm hex key, remove the six M6 screws and six washers securing the inner door to the outer door.
2. Gently lift inner door up and out.

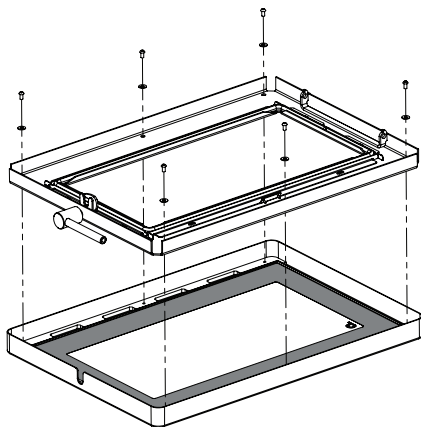

3. Then, gently lift the glass up and out.
4. Fit the new glass and seal into the outer door, with the printed black border facing up. Blaze "b" logo should be oriented as above.

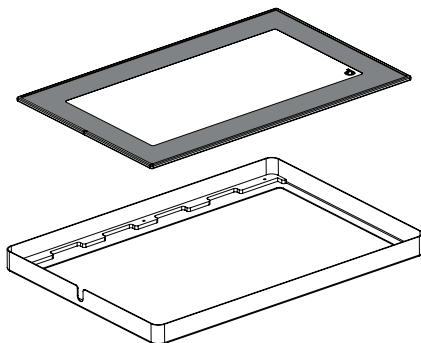

5. Refit the inner door by repeating steps 1 to 2 in reverse order.
6. Dispose of the old glass in a responsible manner.

7. FITTING A NEW DOOR SEAL

This task may be easier with the door removed from the heater and laid flat on a workbench.

1. Remove any old seal from the door.
2. Clean out the groove in the door that the seal was bedded in using a flat-end screw driver or equivalent.
3. Run a thin bead of clear roof and gutter silicone along the groove.

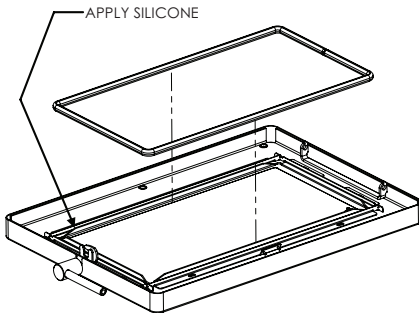

4. Starting at one end, press the new door seal into the groove on the door.
5. Refit the door if it has been removed and close.

8. WARRANTY

Warranty is provided in Australia by Glen Dimplex Australia Pty Ltd (referred as "Glen Dimplex").

This warranty is provided to the first domestic purchaser of a Blaze Wood or Stove Fire (radiant or convection). It applies for 10 years from the date of purchase from or through an authorized Blaze Fire Distributor in relation to each product.

The door glass, door seal, firebricks, brick retainer, and baffle components are covered for normal use only with a 1 (one) year warranty. Electric fans and any remote/transmitter are warranted against failure to operate for a period of 1 (one) year from the original date of purchase. The warranty does not apply to discolouration of the surface or tarnishing of chrome fittings all of which require regular service to maintain. Any breakage or failure due to user error is not covered under this warranty.

TYPE OF PART	WARRANTY (IN YEARS)	
	PARTS	LABOUR
Wood Fire - Firebox	10	5
Door Glass & Seal	1	1
Fire Bricks & Retainer	1	1
Baffle Components	1	1
Fans & Electrical Components	1	1

During the warranty period, Glen Dimplex will repair or replace (at its option) any Blaze Wood or Stove Fire which is found to be defective in materials or workmanship. Repairs will be carried out by an approved Blaze Heating Service Agent.

What is covered under this warranty?

- Repair or replacement of parts
- Labour costs relating to the Wood or Stove Fire

Consumers may have additional rights under the Australian Trade Practices Act 1974 including the Australian Consumer Law or the Consumer Guarantees Act 1993 New Zealand.

This warranty does not apply and will be void where:

- The Wood or Stove Fire is not installed in accordance with AS/NZS 2918:2018 or any building code or consent;
- The Wood or Stove Fire is not installed by a qualified specialist installer;
- Any electrical work has not been carried out by a Registered Electrician;
- The Wood or Stove Fire has been moved and reinstalled, or has been modified in a manner that is not consistent with the Installation Guide or the Owner's Manual;
- The Wood or Stove Fire has not been installed or operated according to the Installation Guide and the Owner's Manual;
- The Wood or Stove Fire is acquired for business use in any way.

What is not covered?

- Labour costs relating exclusively to components not manufactured by Glen Dimplex.
- Labour costs relating to removing or replacing the Wood Fire or Stove
- Damage caused by incorrect use or the burning of treated or painted wood, driftwood or other fuels which are not recommended.

- Travel costs for a distance greater than 50 km from the nearest approved Blaze Heating Service Agent.
- Defects, malfunctions or failures caused by incorrect installation, poor installation, normal wear and tear, misuse, neglect, accidental damage or failure to follow operating instructions in the Owner's Manual (including fuel selection, product operation and maintenance instructions), repairs or modifications by persons not authorised by Glen Dimplex, use of parts not supplied by Glen Dimplex, or damage or other events which have occurred since the product left the control of Glen Dimplex.
- Removal or transportation of such product or part (and any repaired or replacement product or part) to and from the authorized dealer's or service agents place of business.
- Direct, indirect or consequential losses or special damages of any kind (including costs of collection and delivery) other than repair or replacement of products or components under this warranty, where any goods are acquired or used for the purposes of a business;

How to obtain warranty service?

- Warranty Claims must be made at place of purchase.
- Reasonable proof of purchase date is required to make a warranty claim. You should keep your purchase receipt.
- Warranty repair will be completed according to normal work practices of the service agent.
- Make the faulty part(s) available to Glen Dimplex for inspection so that the validity of the claim can be established by them.

9. REPLACEMENT SPARE PARTS LIST

PART NO.	PART	DETAIL
N900-544	Fire Brick Set (Legs/WS)	9 @ 270 x 175 x 25mm
		2 @ 270 x 207 x 25mm
N900-545	Fire Brick Set (Ash)	7 @ 270 x 175 x 25mm
		2 @ 270 x 207 x 25mm
		2 @ 220 x 175 x 25mm
		1 @ 173 x 74 x 25mm
N510-126	Brick Retainer	586 x 370mm steel brick retainer
N510-128	Baffle Kit	543 x 287 x 25mm vermiculite, 2x SS retainers
N211-044	Door Seal	1780mm x 14mm round
N211-049	Glass Seal	2290 x 19 x 3mm flat adhesive backed
N211-028	Door Glass	693 x 442 x 5mm Neoceram Glass
580070	Latch Roller	12mm OD x 9.7mm stainless steel roller
580071	Latch	Steel hex boss
580072	Latch Cap	14.2mm OD x 12mm Steel Cap
N920-015	Latch Nut	M8 nut
N920-147	Latch Screw	M5 X 25mm cap socket screw
N900-534	Door Handle	M8 threaded door handle
N900-529	Door Hook	4mm plate hook
N920-107	Door Handle Nut	M8 prevailing torque nut
N920-067	Washer	M8 spring washer
N900-337	Fan	3 speed
N900-185	Door Handle Extension	Stainless steel handle extension

**Glen Dimplex Australia Pty Ltd**

8 Lakeview Drive,
Scoresby Victoria 3179
Australia

T: 1300 554 155

General & Sales Enquiries: flame.care@glendimplex.com.au

Technical Service: flame.support@glendimplex.com.au

www.glendimplex.com.au